

*****電容器專用接觸器使用說明書*****

*****Capacitor Contactors User's Instruction*****

感謝您選擇東元產品電磁接觸器，請詳細研讀此說明書，並正確使用它。
Thank you for selecting TECO product. Please read this instruction before installation.

注意事項

Attention:

- 若需要檢修時，應先切斷電源再進行檢修。
Turn off power before carrying out any maintenance.
- 使用本產品時，必需小心輕放，避免碰撞及掉落。
Please handle carefully and avoid abnormal vibration and shock.

1. 使用環境

Service Environment:

- 1.1 操作溫度 - 20°C ~ 55°C (Operational Temperature)
- 1.2 儲存溫度 - 40°C ~ 70°C (Storage Temperature)
- 1.3 相對濕度 45% ~ 85% (Relative Humidity)
- 1.4 高度 低於2000m. (Altitude): below 2000m.

2. 安裝及配線

(Installation and Wiring)

- 2.1 確認電磁接觸器規格(主, 補接點容量, 補接點型式, 線圈電壓, 頻率) 是否正確
Ensure that the specifications (Rated power, arrangement of auxiliary contact, rated control voltage and frequency) meet the requirements.

- 2.2 依規定方式安裝, 安裝角度須在圖示範圍內:
Mounting positions shall be within the ranges specified
Figure to the right :

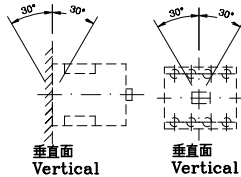

- 2.3 配線時依規格選用壓接端子及配線之線徑, 並依序進行配線
Select appropriate conductor and tighten with appropriate torque with right tool.

- 2.4 依右表鎖線時, 鎖線扭力值如表
Tightening torques for contactors are given Form to the right :

*鎖線扭力請勿大於上述扭力值, 以免造成螺絲滑牙現象
Tightening torque shall be within the values given above to avoid deteriorating the screws.

*電源側, 負載側配線時若不易安裝, 可先將補接點拿起, 待配線完畢後再裝回

If supply side and load side wiring not easy, auxiliary to pick up until the wiring is completed, then put it back

機種 Type	項目 Item	螺絲尺寸 Screw/blot	鎖緊扭力(kgf.cm) Tighting torque
CU-11C	主迴路端子 Main Terminal	M3.5	23
CU-17C	主迴路端子 Main Terminal	M3.5	23
CU-18C	主迴路端子 Main Terminal	M4	30
CU-32C	主迴路端子 Main Terminal	M5	40.5
CU-50C/55C/60C	主迴路端子 Main Terminal	M6	58
全系列 All Series	補助接點及 線圈端子 Auxiliary contact & coil terminal	M3.5	7.5 ~ 11.5

- 2.5 頂裝式接點組為使用於切換電容專用, 引線組安裝如圖示:

Top Mounting contact set for switching the capacitor only, the lead wire fixed as following figures:

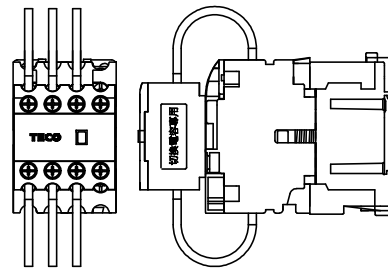

- *主迴路導線安裝在電磁接觸器本體上, 切勿安裝於頂裝式接點組。
The main circuit wire is installed on the electrical contactor body, do not install it on the top-mounted contact group.

- 3. 更換補b接點組

(Installation of auxiliary N.C contact assembly if required.)

Assemble the auxiliary N.C contact assembly according to the steps shown in figures following if required.

(Press down movable contact carrier)

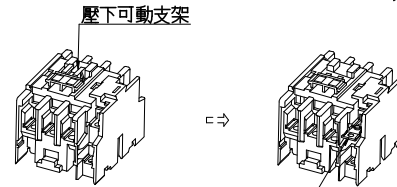

STEP: (1) (2) 裝入補b接點組 (3)
(Insert auxiliary N.C contact assembly)

- 4. 更換線圈

Replacement of the coil:

若有必要更換線圈時, 必須注意下列事項

Follow the instructions if replacement of the coil is carried out.

- 4.1 正確的將產品拆解
Dismantle the contactor in appropriate means.
- 4.2 將原有線圈更換至所需求規格(額定電壓, 頻率)的線圈
Replace the coil to requested coil.
- 4.3 依4.1步驟之反相動作將產品重新組合。
Assembly the contactor in a reverse sequence conducted in step 4.1.
- 4.4 測試產品能正常動作。

Check that the contactor can be operated normally.

- * 使用本產品若有不清楚時, 請參閱產品型錄或洽詢公司營業人員。
For more information, please see the catalogue or contact sales people.

TECO ELECTRIC & MACHINERY CO., LTD.
15 Chung-hwa Rd., Hsinchu Industrial Park, Taiwan, R.O.C.
TEL: 886-3-5981711 FAX: 886-3-5982488
W www.teco.com.tw

**2.6 線路圖
(Cabling)**

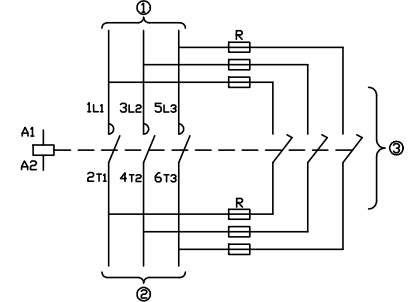

- ① 電源側
Supply
- ② 負載側
Load
- ③ 補接點請勿額外連接線路
Auxiliary don't connect anything
- R 限流電阻
Resistance

放開可動支架確認
電磁接觸器動作正常
(Release movable contact carrier and check auxiliary N.C contact assembly is close.)