

FG-24B適用(TO-400E/S,TG-400H,TMP-400S)

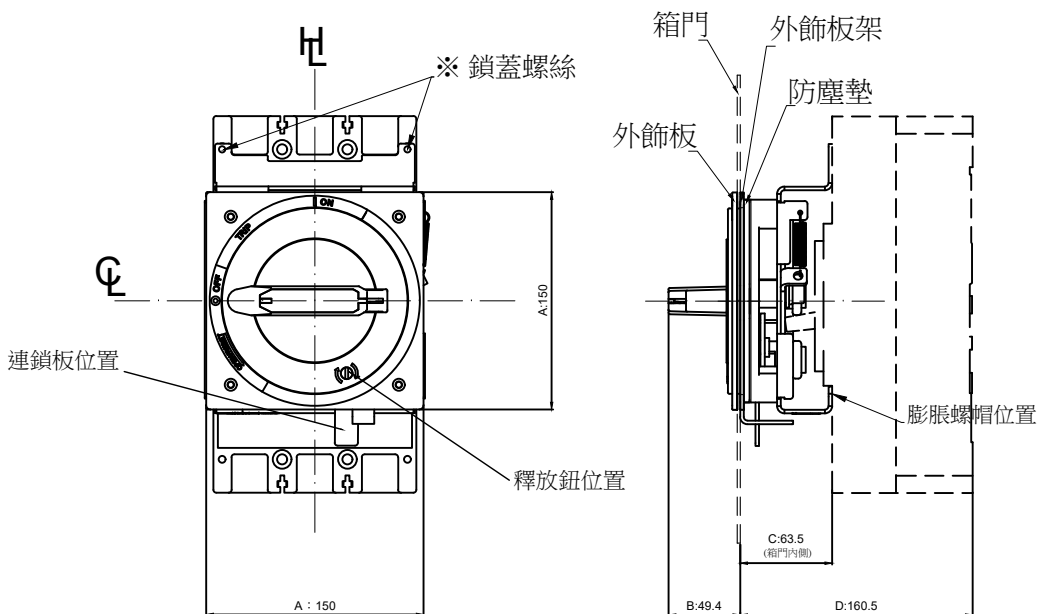

盤面孔位

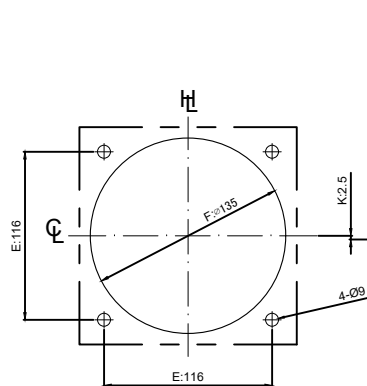

MCCB固定孔

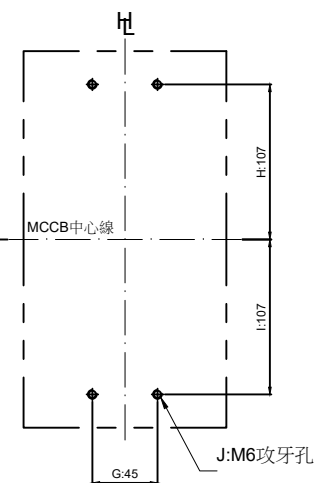

鉸鏈之距離

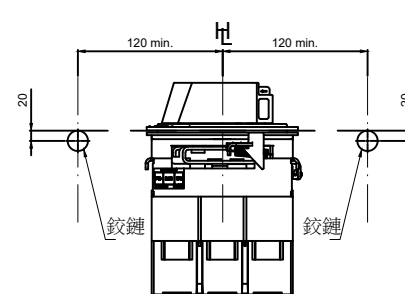

FG-2 型式	適用之無熔線斷路器	外型尺寸 (mm)										掛鎖 直徑	把手 固定螺絲	
		A	B	C	D	E	F	G	H	I	J			K
FG-24B	TO-400E/S,TG-400H,TMP-400S	150	49.4	63.5	160.5	116	135	45	107	107	M6	2.5	Φ5~Φ8	M4x8(2支) M4x55(2支)

註：1."B"尺寸為防塵墊被箱門擠壓1.0mm。
2."HL"表示為把手中心線；"CL"表示為產品中心線。

掛鎖方式

