

FG-25B適用(TO-630EB/800EB/600S/800S, TG-600H/800H/630HB/800HB, TE-600/800)

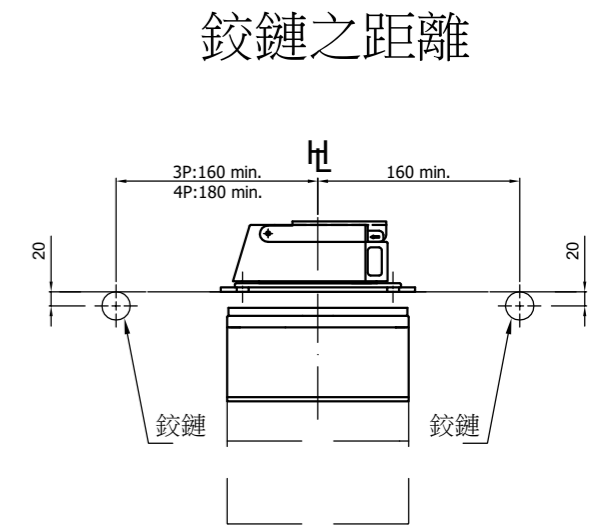

| FG-2<br>型式 | 適用之無熔線斷路器  | 外型尺寸(mm) |      |      |       |     |     |    |       |       |    |    | 掛鎖<br>直徑 | 把手<br>固定螺絲 |           |
|------------|--|----------|------|------|-------|-----|-----|----|-------|-------|----|----|----------|------------|-----------|
|            |  | A        | B    | C    | D     | E   | F   | G  | H     | I     | J  | K1 |          |            | K2        |
| FG-25B     | TO-630EB/800EB/600S/800S<br>TG-600H/800H/630HB/800HB, TE-600/800 | 150      | 51.5 | 62.5 | 162.5 | 116 | 135 | 70 | 121.5 | 121.5 | M8 | -- | 2.6      | Φ5~Φ8      | M5x63(4支) |

註：1."B"尺寸為防塵墊被箱門擠壓1.0mm。  
2."HL"表示為把手中心線；"CL"表示為產品中心線。

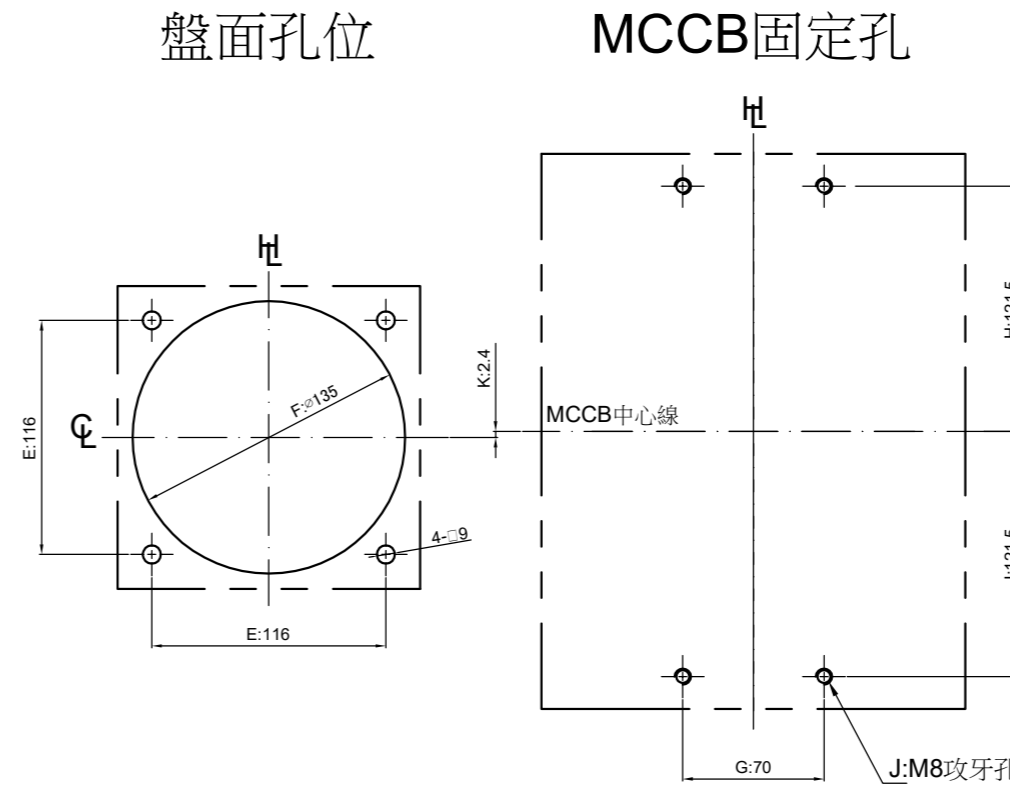
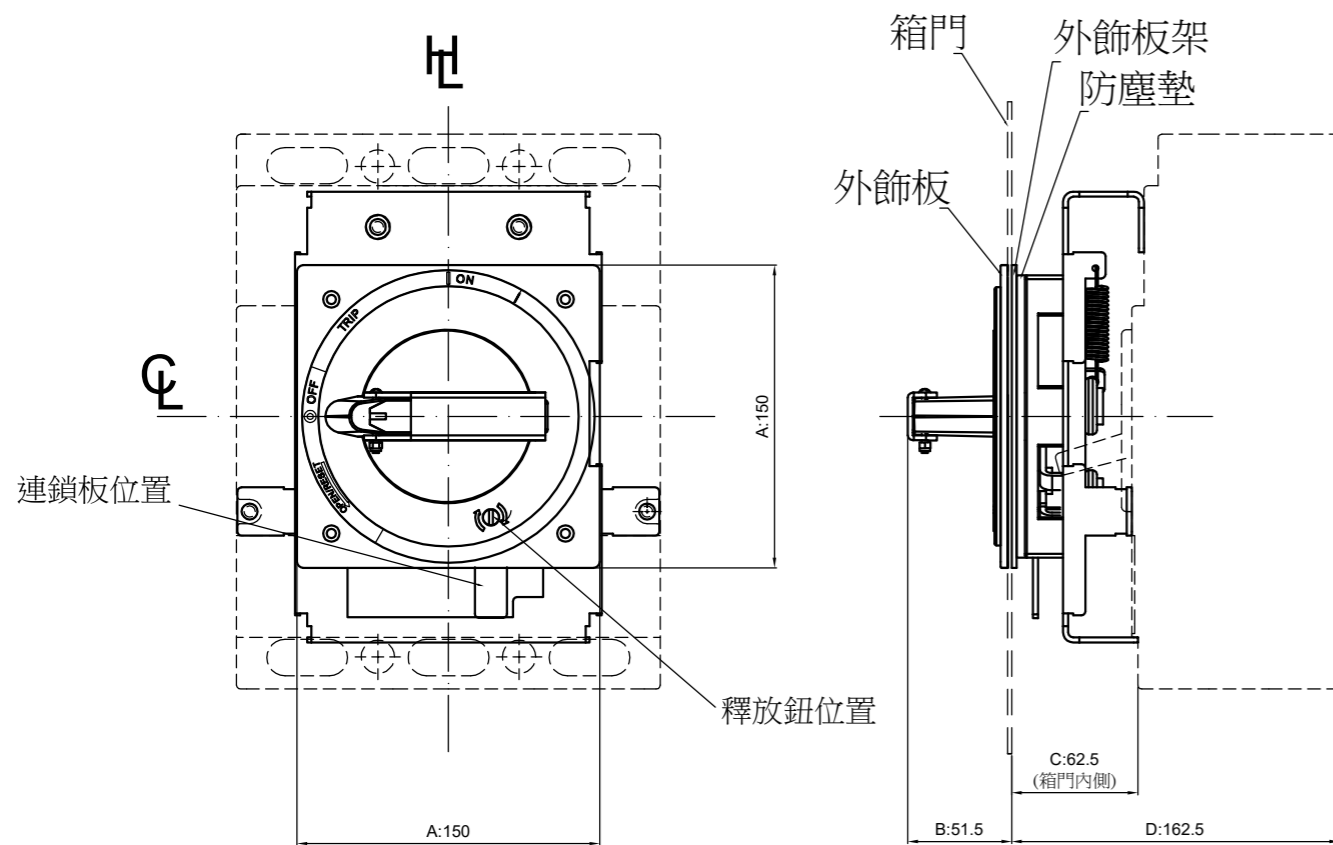