

CNA-2M/4M 使用說明書

CNA-2M/4M User's Instruction

注意(Caution) ⚠

感謝您選擇東元產品, 請詳細研讀此說明書, 並正確使用它。

Thank you for selecting TECO product. Please read this instruction before installation.

— 若需要檢修時, 應先切斷電源再進行檢修。

— Turn off power before carrying out any maintenance.

— 使用本產品時, 必需小心輕放, 避免碰撞及掉落。

— Please handle carefully and avoid abnormal vibration and shock.

*CN-5(K)/6(K)與CNA-2M/4M組裝方法

*CN-5(K)/6(K) and CNA-2M/4M Assembly method.

① 依箭頭方向將CNA-2M/4M插入組合

Follow the direction of arrow to install CNA-2M/4M.

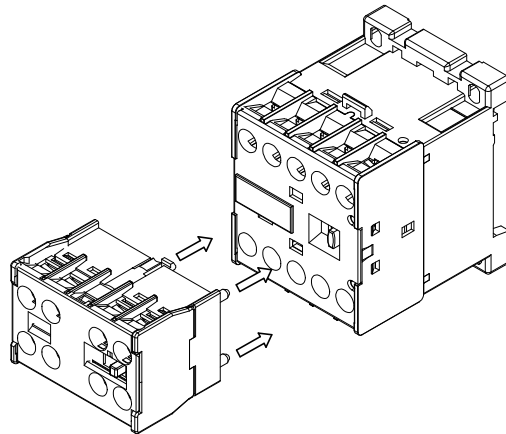

② 撥動投入指示確認是否安裝定位

Toggle the input instructions to confirm whether to install the positionion.

* 依下表鎖線時, 鎖線扭力值如下:

Tightening torques for contactors are given below:

機種 Type	項目 Item	螺絲尺寸 Screw/blot	鎖緊扭力(kgf.cm) Tightening torque
CNA-2M/4M	補助接點 Auxi contact	M3.5	7.5 ~ 11.5

* 使用本產品若有不清楚時, 請參閱產品型錄或洽詢公司營業人員。

For more information, please see the catalogue or contact sales people.

T 886-3-598-1711 F 886-3-598-2488

WWW.teco.com.tw

TECO ELECTRIC & MACHINERY CO., LTD.

FM3 40A203A100