

Modular Power Conditioning System Installation and Maintenance Manual

TE-PCS-100K-HM · TE-PCS-150K-HM
TE-PCS-175K-HM · TE-PCS-200K-HM

Version 01



Installation Manual

01

1. Appearance	
1.1. Appearance and Structure	1-2
1.2. Strip indicator panel	1-3
1.3. COM1/COM2 Communication port	1-4
1.4. Size	1-5
2. Installation Preparation	
2.1. Installation Environment	1-6
2.2. Packing List	1-6
2.3. Installation Space	1-7
3. Mechanical Installation	1-8-1-9
4. Electrical Connection	1-8-1-9
4.1. Requirements for Wire	1-10
4.2. External Grounding Connection	1-11
4.3. AC Wiring	1-12
4.4. DC Wiring	1-13
4.5. COM Communication Connection	1-14
4.6. Ethernet Communication Connection	1-15

Maintenance Manual

02

1. Product Intro	
1.1. Integrated system	2-2
1.2. Efficient and smart	2-2
1.3. Flexible and conveniently	2-2
2. Electrical grid format	2-2
3. Appearance	
3.1. Appearance and Structure	2-3
3.2. Size	2-6
4. Working Principle	
4.1. Grid-tied mode	2-7
4.2. Off-grid mode	2-7
5. Grid-tied mode	
5.1. Communication with Upper-computer	2-8
5.2. Communication with BMS	2-10
5.3. Meter Communication (Optional)	2-10
6. Startup and Shutdown	
6.1. Check Before Startup	2-11
6.2. Start the PCS	2-11
6.3. Shut Down the PCS	2-12
7. WEB Operation	
7.1. Communication Wire Connection	2-13
7.2. Communication Settings	2-13
7.3. Login	2-14
7.4. Unit Running Info	2-16
7.5. System Info	2-17
7.6. Basic Setting	2-18
7.7. Battery Setting	2-20
7.8. Profit Setting	2-20
7.9. Communication Setting	2-22
7.10. Local Setting	2-23
7.11. Event Record	2-23
7.12. Energy Correction	2-23
7.13. Record Management	2-24
7.14. Modify Password	2-24
8. Maintenance and Troubleshooting	
8.1. Maintenance	2-25-2-28
8.2. Troubleshooting	2-29-2-32

Installation Manual



Attention

The products, services, or features you purchase are subject to the commercial agreements and terms entered into with TECO Company.

All or part of the products, services, or features described in this document may not be included within the scope of your purchase or use. Unless otherwise expressly agreed, TECO Company makes no express or implied representations or warranties regarding the contents of this document.

Due to product version upgrades or other reasons, the contents of this document may be updated from time to time without prior notice unless otherwise agreed.

This document is provided for reference and guidance only. All descriptions, information, and recommendations contained herein do not constitute any express or implied warranty.

1. Appearance

1.1. Appearance and Structure

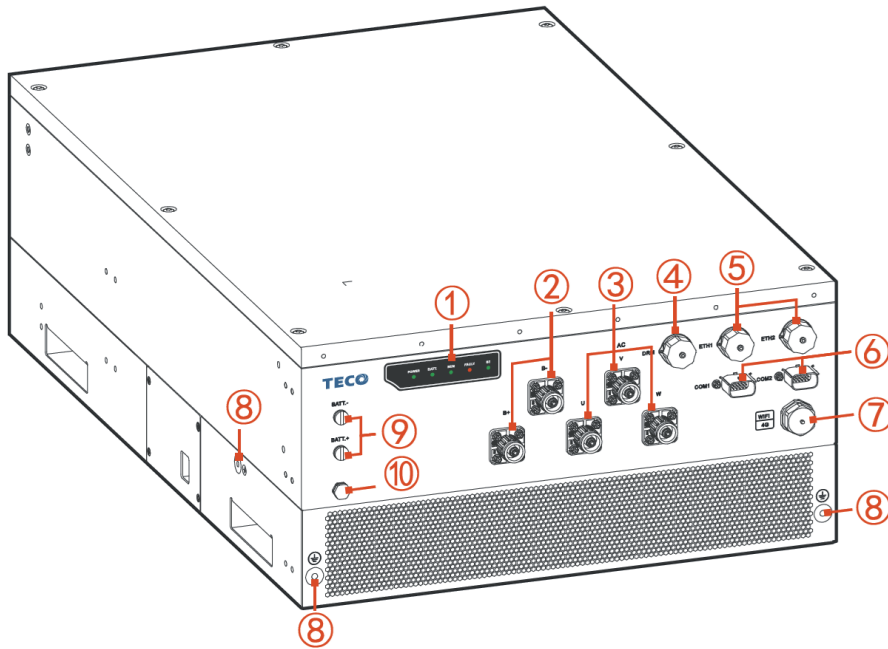

No.	Mark	Name	Illustration
①	-	Strip indicator panel	Indicate the work status of PCS.
②	B+/B-	DC terminals	Wiring terminals of DC side.
③	AC U(R) / V(S) / W(T)	AC terminals	Wiring terminals of AC side.
④	DRM	DRM port (reserved)	Reserved port for DRM function.
⑤	ETH1 / ETH2	Ethernet port	Used to connect with upper-computer. Ethernet is mainly used for LAN monitor, and realize remote monitor.
⑥	COM1 / COM2	Communication port	COM2: Used for BMS communication. COM1: Reserved port for communication.
⑦	WIFI / 4G	Wireless communication port	Used for wireless communication.
⑧		Grounding terminal of wiring side	Used to connect the PCS with ground.
⑨	BAT.+ / VAT.-	Waterproof plug	Reserved port for battery voltage sampling (optional).
⑩	-	Breather valve	Used to balance the pressure difference between inside and outside of the PCS.

1.2. Strip indicator panel

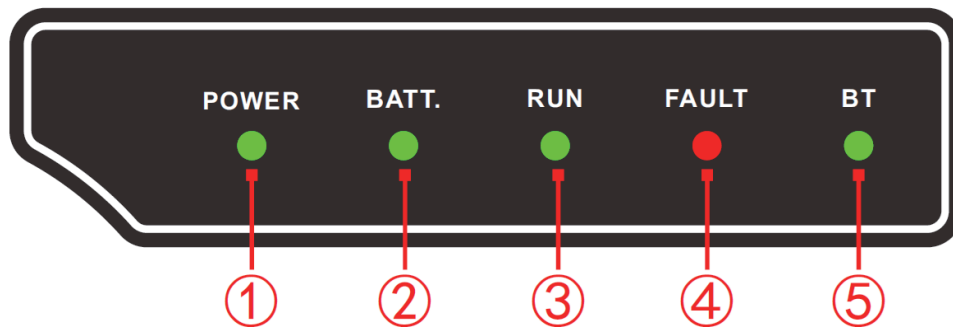

No.	Mark	Color	Name	Status illustration
①	POWER	Green	Operation power indicator	On: the inner power of the PCS has been established. Off: the inner power of the PCS has not been established.
②	BATT.	Green	Battery connection indicator	On: the battery has been connected and meets the work condition. Off: the battery voltage does not meet the work condition.
③	RUN	Green	Running status indicator	On: in grid-tied operating status. Flicker: standby or OFF Off: AC and DC terminals not connected.
④	FAUTL	Red	Fault alarm indicator	On: there is fault on PCS Flicker: there is alarm on PCS Off: there is no fault or alarm
⑤	BT	Green	Bluetooth indicator	On : Bluetooth connection is normal Flicker : Bluetooth waiting to connect Off : Bluetooth power not established

1.3. COM1/COM2 Communication port

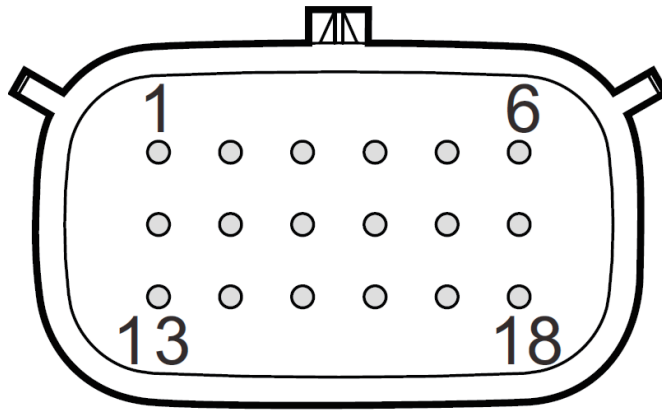

Pin	Function definition	Illustration	
Pin1	Passive input dry contact port 1	Pin1 and Pin4 is a group of EPO dry contact ports for PCS.	
Pin2	BMS serial communication port	BMS_RS485_B. It is used with Pin5 (RS485_A) together.	
Pin3	BMS CAN communication port	CAN_L. It is used with Pin6 (CAN_H) together.	
Pin4	Passive input dry contact port 1	Pin1 and Pin4 is a group of EPO dry contact ports for PCS.	
Pin5	BMS serial communication port	BMS_RS485_A. It is used with Pin2 (RS485_B) together.	
Pin6	BMS CAN communication port	CAN_H. It is used with Pin3 (CAN_L) together.	
Pin7	Passive input dry contact port 2	Pin7 and Pin8 is a group of EPO dry contact ports for PCS.	
Pin8		If the Ports need to be used, please contact our company.	
Pin9	Upper-computer serial communication port	PC_ISO_A (RS485)	
Pin10		PC_ISO_B (RS485)	
Pin11	Reserved external BMS power supply port	+24V_IOS_BMS	If this function needs to be used, please contact our company.
Pin12		0V	
Pin13	Active input dry contact port	+24V	Pin13 and Pin14 is a group of active EPO dry contact ports for PCS.
Pin14		0V	

Pin	Function definition	Illustration	
Pin15	Reserved external BMS power supply port	+24V_IOS_BMS	If this function needs to be used, please contact our company.
Pin16		0V	
Pin17	Meter communication port(optional)	Meter communication port RS485 A	
Pin18		Meter communication port RS485 B	

1.4. Size

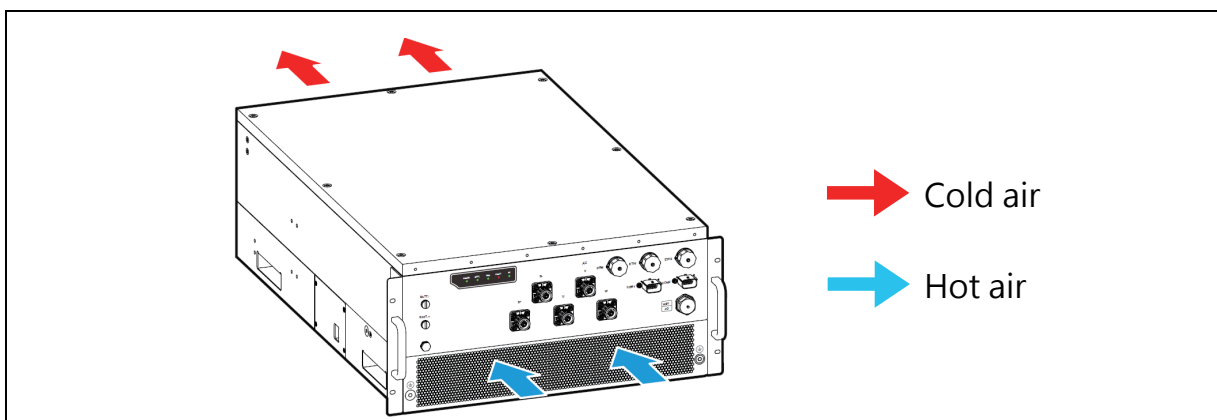
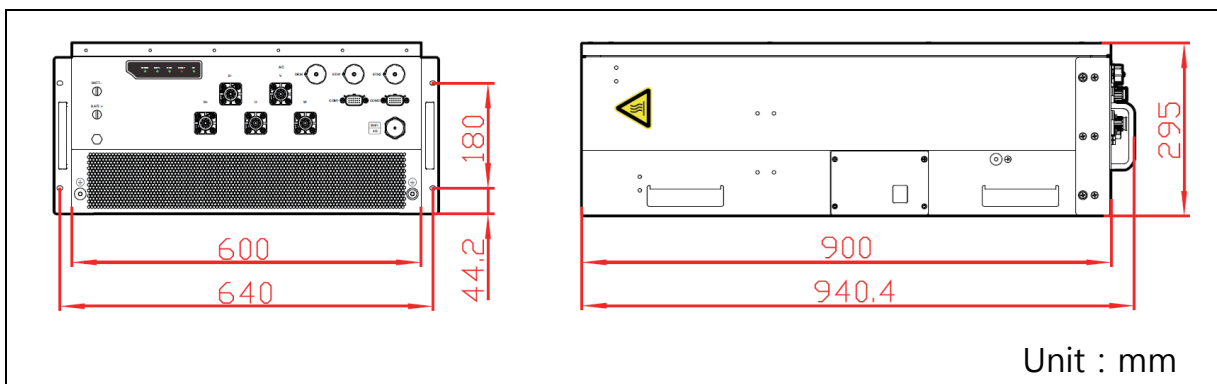

2. Installation Preparation

2.1. Installation Environment

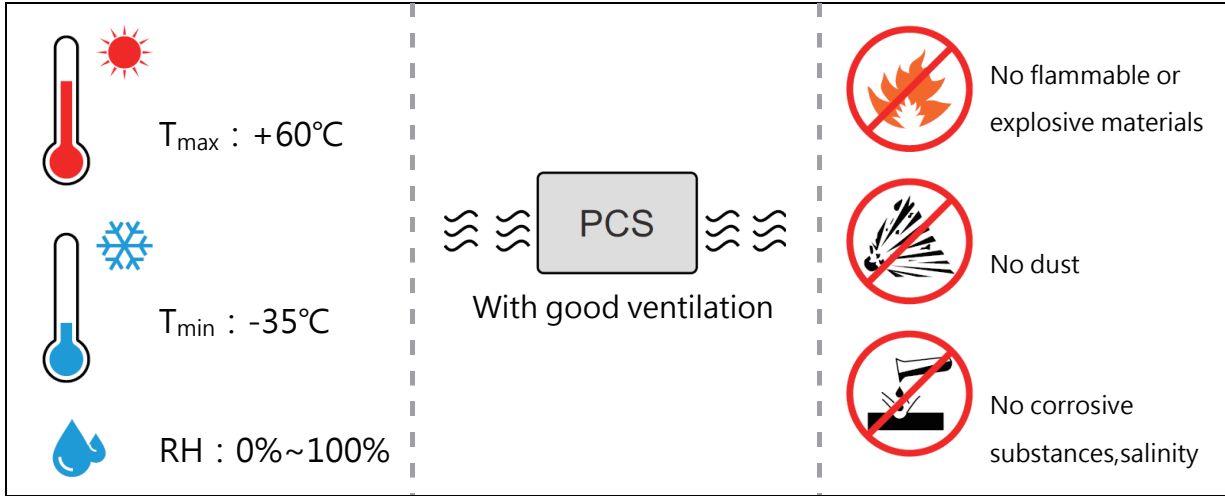

2.2. Packing List

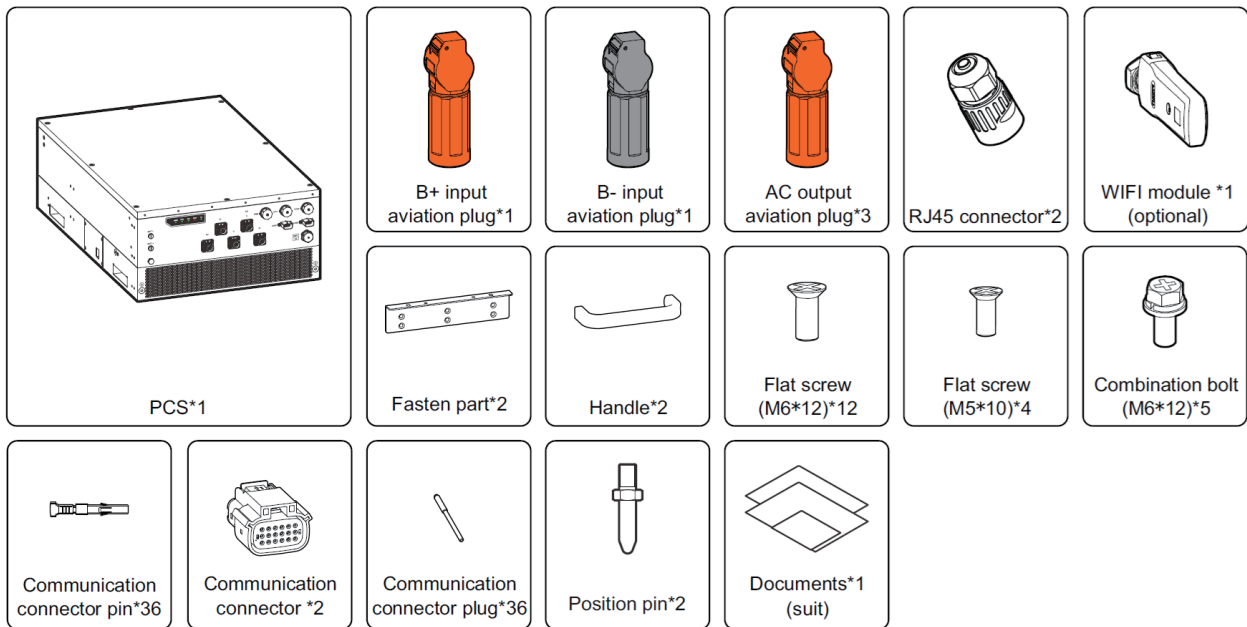

 CAUTION

After unpacking, if the PCS will be stored for a long time, it's recommended to pack the PCS by original plastic package.

2.3. Installation Space

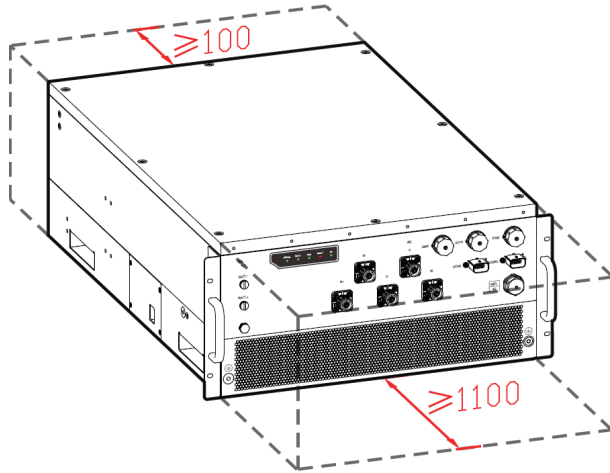

Unit : mm



NOTE

When installing the PCS in an energy storage system, ensure the following guidelines are met for optimal performance and safety:

1. Ventilation: Design ventilation holes in the front of the energy storage system. Maintain a minimum distance of 100mm between the front of the PCS and the energy storage system.
2. Air flow: 900m³/h.
3. Air inlet area: Not less than 250 mm × 700 mm, ventilation rate not less than 60%.
4. Air outlet area: Not less than 1.2 times the air inlet area.
5. Additional recommendations:
 - Consider installing a cover at the PCS air outlet.
 - It's recommended to add a sunshade or heat insulation foam around the PCS to protect against heat exposure.

3. Mechanical Installation

Step1. Install the two fasten parts by six flat screws M6*12 onto the PCS.

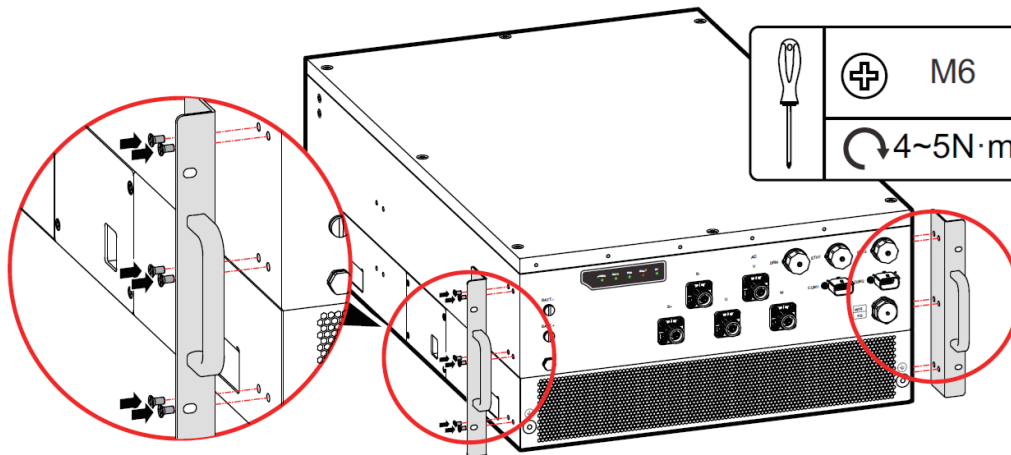

NOTE

- When the PCS is installed into the energy storage system and needs to be transported with the system together, we suggest to fix the PCS by position pins. The PCS has two holes at the back of the PCS (size as follows) to fix the position pins.
- The position pins are prepared in the accessory.

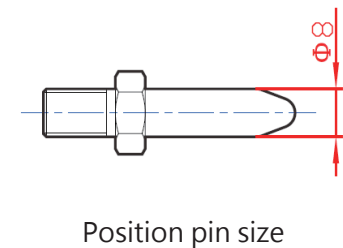
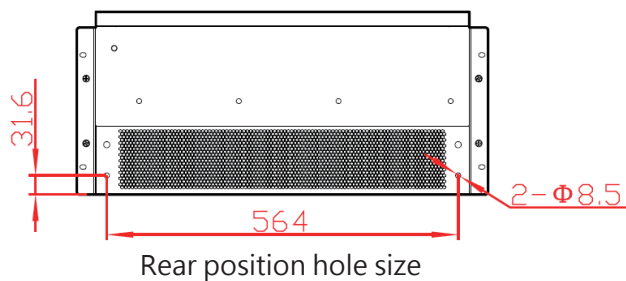

Step2. Push the PCS along the guide rail into the cabinet.

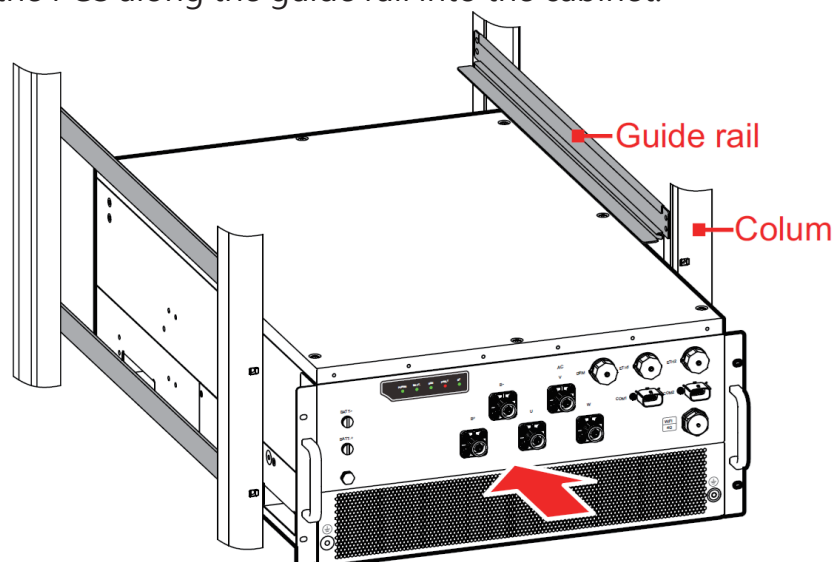

Step3. Fix the PCS onto the column by four M6*12. (41~51 kgf · cm) °

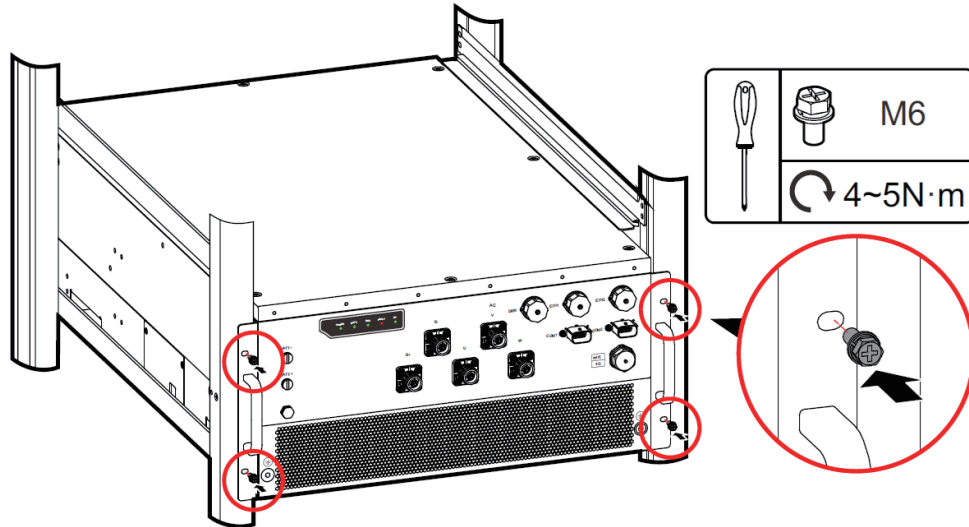

 **NOTE**

The PCS also supports side stand mounting. If the PCS adopts side stand mounting, we suggest to use tray to fix it (as follows).

The rail guide should avoid the fasten parts and the screws at the top of the PCS, the corresponding size as follows. The tray must be fixed by four screws M6 at least.

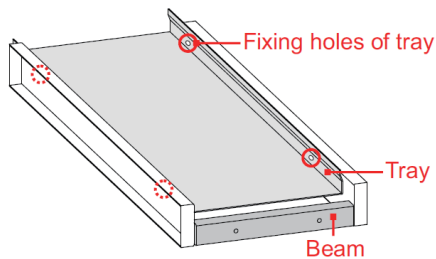

Tray diagram

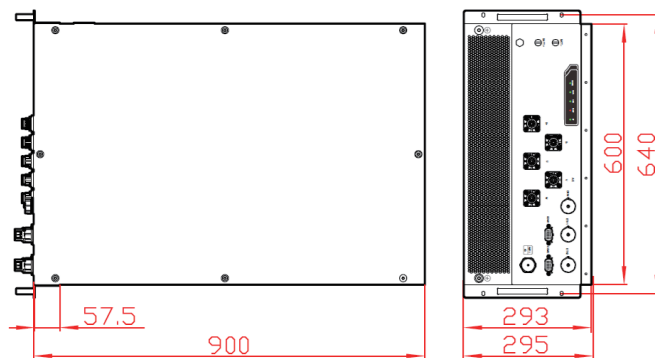

Installation size of side stand mounting

4. Electrical Connection



CAUTION

- High voltage may exist inside the PCS.
- Do not close the external DC switch and external AC breaker before completing the electrical connection.
- Make sure that all cables without electricity before wiring.
- Any improper operation during wiring may cause device damage or human injury, so, wiring operation must be performed only by professional technicians.
- The cables used in the energy storage system must be firmly connected, well insulated and with proper specifications.
- The wiring process must follow the relevant rules of the local power grid and the relevant safety instructions of the energy storage battery.
- All electrical installations must comply with the electrical standards of the country or local region where the project located.
- The PCS can be integrated into the power grid after obtaining permission from the local power department.

4.1. Requirements for Wire

Name	Type	Recommended specification (mm ²)
DC input wire	1500V and above outdoor cables	Outdoor single-core cable: 70
AC output wire	690V and above outdoor multicore cable or single-core cable	Outdoor single-core cable: 70
Ethernet communication wire	8-core network cable	-
RS485/CAN communication wire	Shielded twisted pair	2*0.3 mm ² (max outer diameter <14mm)
External grounding wire	Outdoor cable	Conductor cross-sectional area $\geq S/2$ (S is the conductor cross-sectional area of AC output wire)



NOTE

- The cables in above table are based on UL copper wire. If other wires are used, please replace them according to the standard.
The wire materials selected by our company have passed the national standard certification or UL certification.
- If the recommended terminal model is not adopted, please confirm with our company.
- If aluminum wire is used, it should adopt copper-aluminum transition terminal to avoid the copper bar come into contact with the aluminum wire directly.
- The cables above should be prepared by user.

4.2. External Grounding Connection



CAUTION

Before connecting the wiring of AC, energy storage battery and communication, please connect the external grounding wire first. °

Step1. Strip the insulation layer of the grounding wire by crimping tool, and press it into the corresponding terminal. °

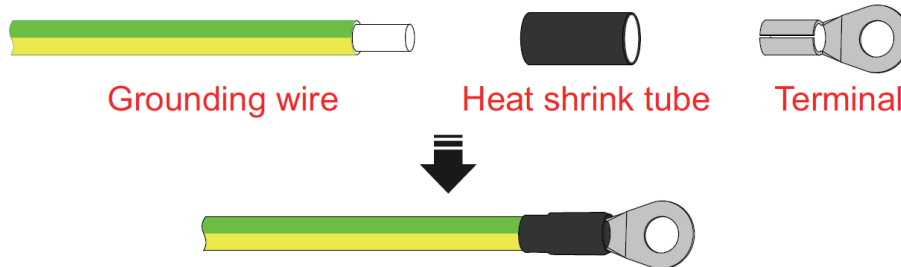

Step2. Connect the crimped grounding wire to the external grounding terminal of the PCS.(41~51 kgf · cm)

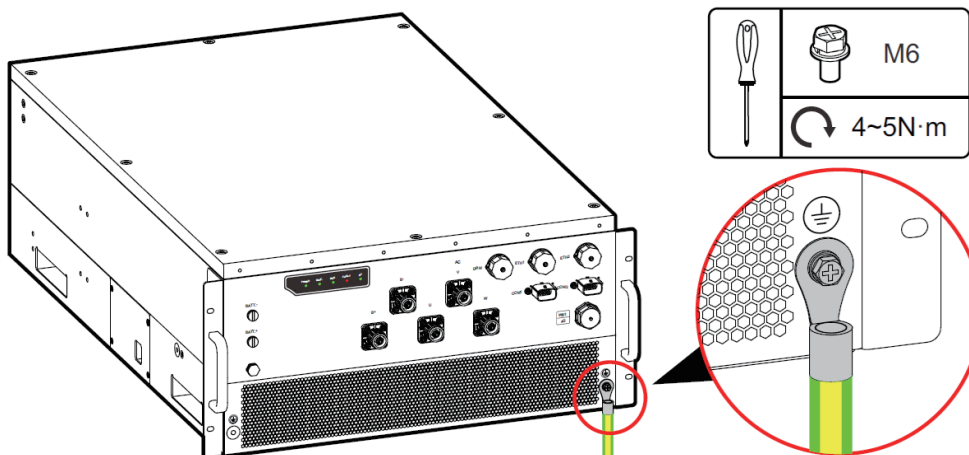

NOTE

- The PCS designs 4 external grounding terminals (as shown in 1.1 Appearance and Structure), before electrical connection, connect the grounding terminal to the grounding cooper bar on the site reliably.
- It is recommended to use DT or OT terminal for the external grounding wire.
- In order to improve the anti-corrosion performance of the grounding terminal, it is recommended to paint anti-rust paint on the outside of the grounding terminal for protection after installation.



CAUTION

- The grounding of the PCS and the lightning rod of the building that the PCS installed cannot be the same, the two need to be separated (as follows), or lightning stroke will damage the PCS.
- The grounding of the PCS should be directly connected to the grounding system, and the impedance should be less than 20mΩ.

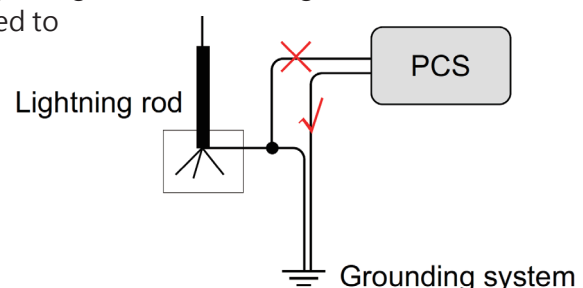

4.3. AC Wiring

 **NOTE**

- The output side of the PCS should configure external breaker.
- Before connecting with grid, please make sure that the grid voltage and frequency are all meet there quirements of the PCS.

Step1. Turn the external DC switch and external AC breaker to OFF.

Step2. Crimp the AC cables (U, V, W) into the aviation plugs.

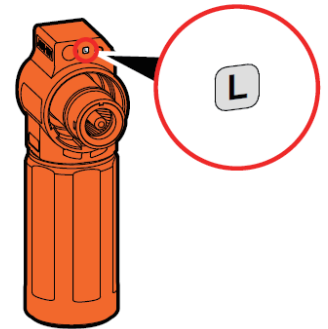

Mark of aviation plug AC U/V/W

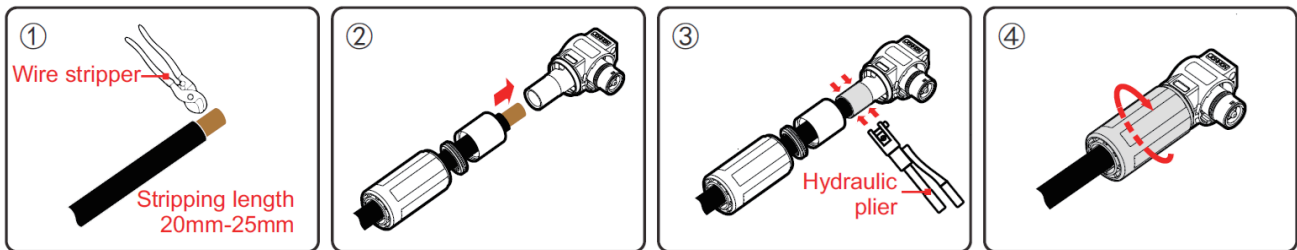

Step3. Connect the crimped AC cables to the AC ports(U, V, W) of the PCS.

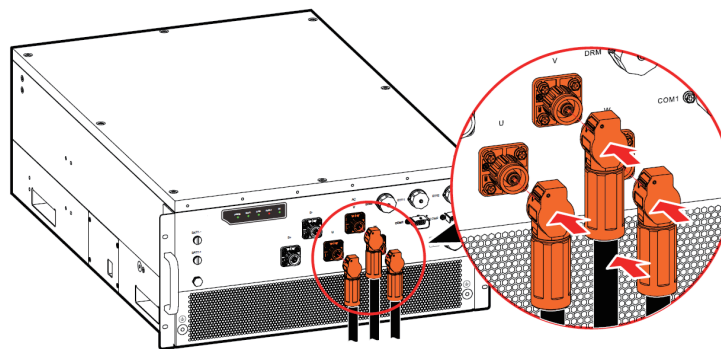

If the AC cables need to be disconnected, please press the button at the side of aviation plug (as below) first to pull it out.

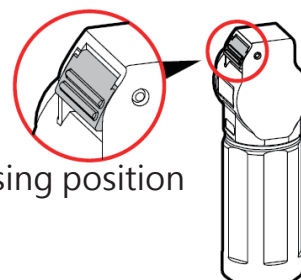

 **CAUTION**

Avoid pressing the insulation layer of the cables. Improper connecting operation may cause the PCS fail to operate normally.

4.4. DC Wiring

 **NOTE**

The DC side of the PCS should configure external breaker.

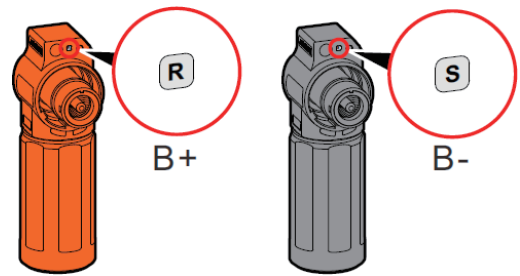

Mark of aviation plug B+, B-

Step.1 Check whether the polarity of the energy storage battery is correct.

Step.2 Crimp the battery +, - cables into the aviation plugs.

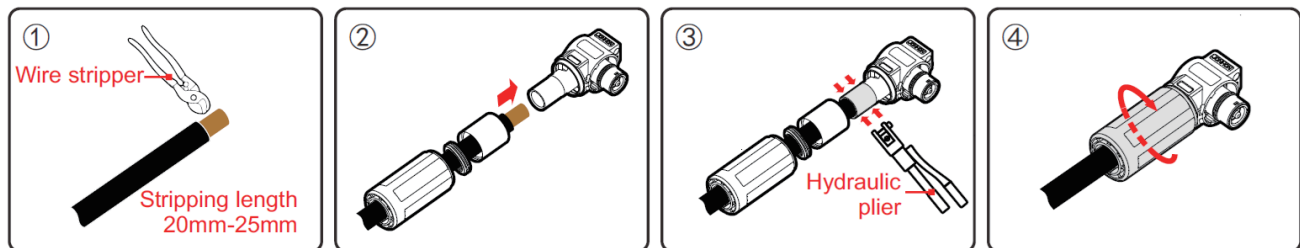

You can distinguish the aviation plug B+/B- via the mark on the plug, as follows.

Step.3 Connect the crimped battery cables to the DC ports (B+, B-) of the PCS.

When connecting, a click will sound to indicate well connection of aviation plug.

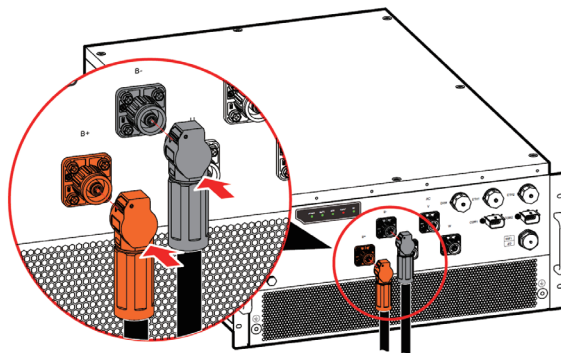

If the DC cables need to be disconnected, please press the button at the side of aviation plug (as below) first to pull it out.

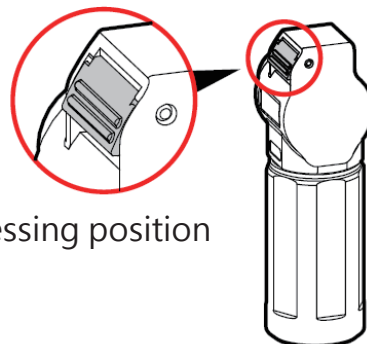

Pressing position

 **CAUTION**

When wiring, ensure that the insulation between positive cables and negative cables is well. Once the positive and negative short, it will cause the PCS permanent damage.

4.5. COM Communication Connection

Step.1 Crimp the communication wires to the contact pin of connector.

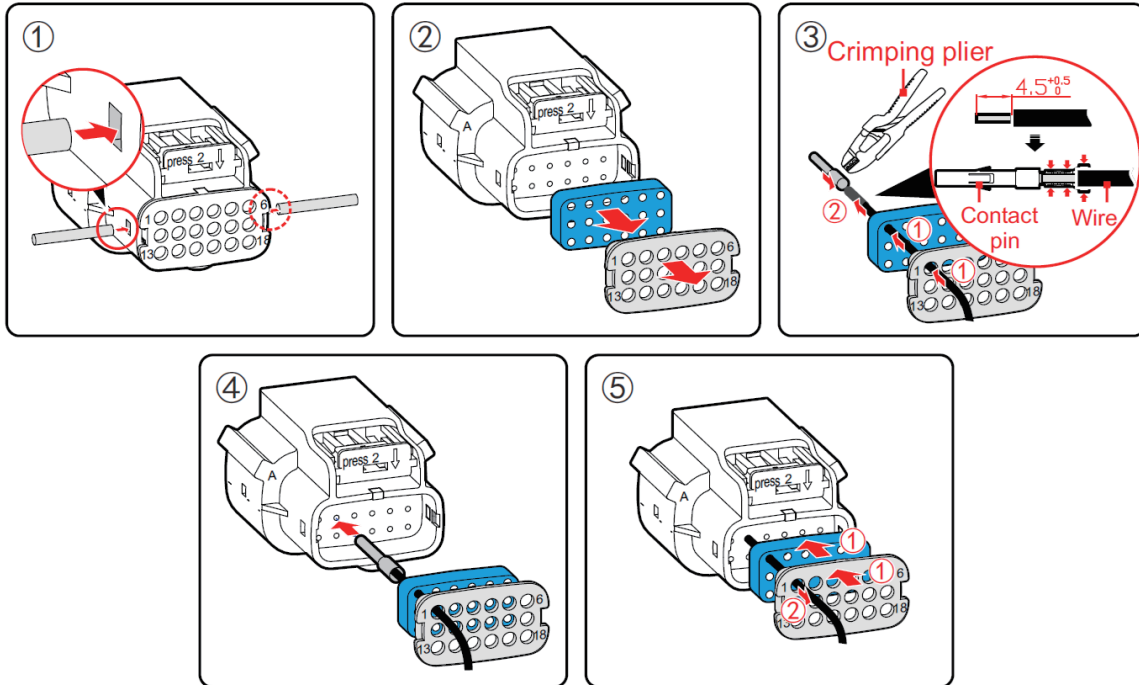

Step.2 Connect the crimped connector to corresponding port of PCS, and press the buckle to avoid loosening.

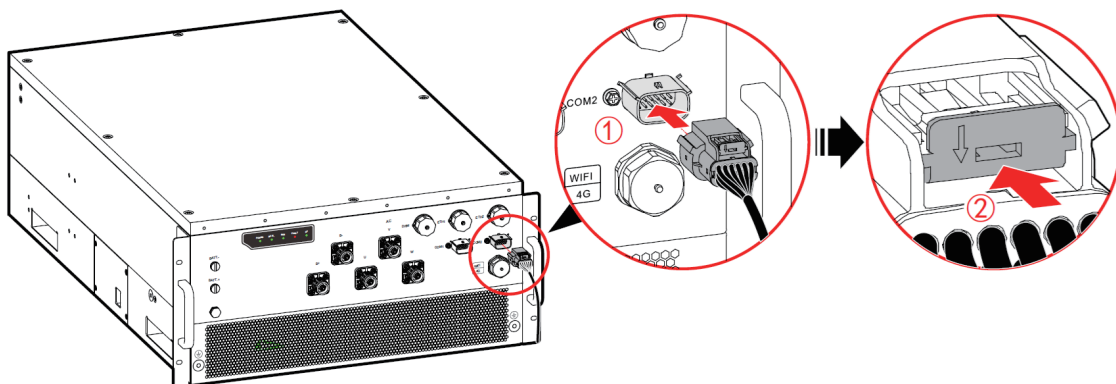

CAUTION

- While connecting the terminals, avoid crimping the insulation layer, or that may cause bad contact.
- The communication wires should be separated from input and output cables to avoid communication interference.
- The holes not used in COM port, must be blocked by plugs.

4.6. Ethernet Communication Connection

Step.1 Crimp the Ethernet wires into RJ45 plug.

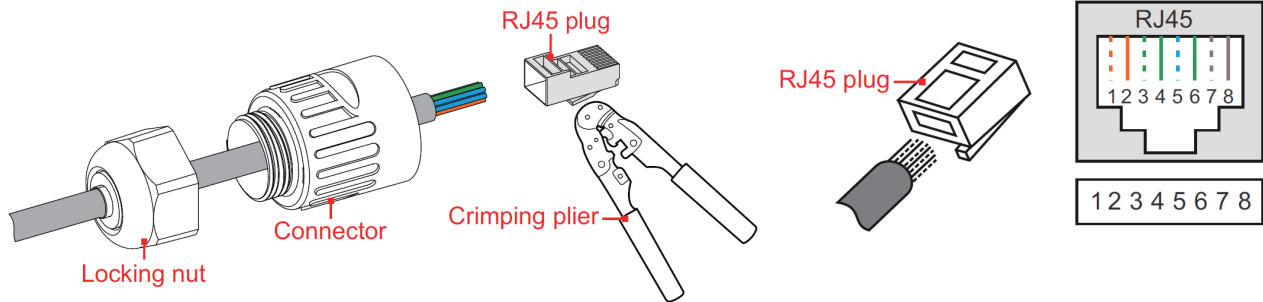

Step.2 After crimping, insert the RJ45 plug into the buckle, and then screw the RJ45 port.

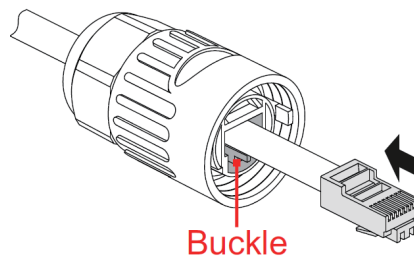

Step.3 Connect the crimped Ethernet communication wire to the ETH port of PCS.

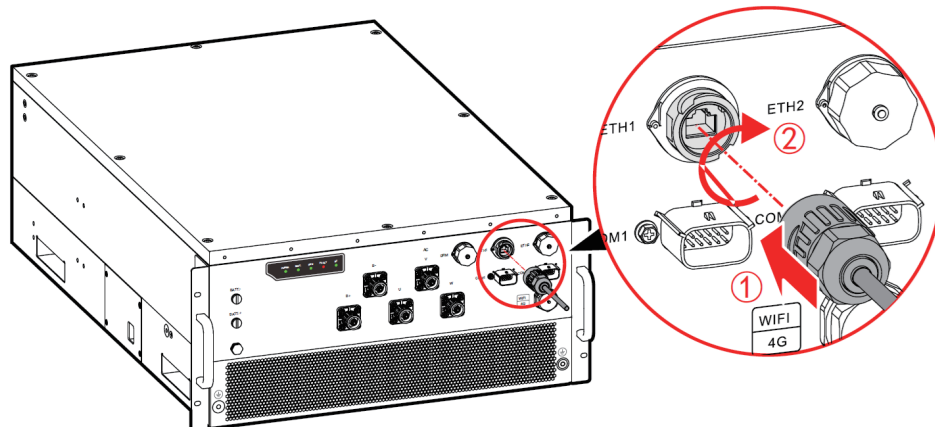

NOTE

The default IP of ETH1 port on the PCS is 192.168.28.240, the default IP of ETH2 port on the PCS is 192.168.28.241.



CAUTION

Ensure that the cover of unused ETH port is screwed on tightly.

Operation and Maintenance Manual

Attention

The products, services, or features you purchase are subject to the commercial agreements and terms entered into with TECO Company.





All or part of the products, services, or features described in this document may not be included within the scope of your purchase or use. Unless otherwise expressly agreed, TECO Company makes no express or implied representations or warranties regarding the contents of this document.

Due to product version upgrades or other reasons, the contents of this document may be updated from time to time without prior notice unless otherwise agreed.

This document is provided for reference and guidance only. All descriptions, information, and recommendations contained herein do not constitute any express or implied warranty.

Symbol Conventions :

The manual quotes the safety symbols, these symbols used to prompt users to comply with safety matters during installation, operation and maintenance. Safety symbol meaning as follows.

Symbol	Description
 DANGER	Alerts you to a high risk hazard that will, if not avoided, result in serious injury or death.
 WARNING	Alerts you to a medium low risk hazard that could, if not avoided, result in moderate or minor injury.
 CAUTION	Alerts you to a low risk hazard that could, if not avoided, result in minor injury.
	Anti-static prompting.
	Be care electric shock prompting.

Applicable Model :

TE-PCS-100K-HM
 TE-PCS-150K-HM
 TE-PCS-175K-HM
 TE-PCS-200K-HM

Summaries :

The illustrations in this manual are for illustrative purposes only; the actual product received shall prevail.

1. Product Intro

1.1. Integrated system

- Modular design, and can be matched and integrated with battery system conveniently and flexibly.
- With built-in DC pre-charge function, for user's battery, it no needs to configure independent buffer circuit, and can be used immediately after inserting, which is safe and reliable.

1.2. Efficient and smart

- Efficient three level design, the max. efficiency > 98.8%.
- Advanced midpoint potential balance control technology, effectively reduce the ripple voltage and improve the service life of bus capacitors.
- With the function of fault wave capture / remote online update.
- Smart management, and the meter can be connected to achieve anti-backflow function.

1.3. Flexible and conveniently

- Convenient modular design, which makes the installation more easily, and decrease the maintenance costing.
- Support the AC parallel operation of several PCS. The system scheme configuration is flexible.
- With independent design of fan module to realize the quick installation and maintenance.
- With IP66 design, can adapt various wicked environment.

2. Electrical grid format

The recommended grid configuration on the PCS AC side is an IT power distribution system. The power system is isolated from the earth, while the equipment is directly connected to the earth. The equipment grounding is independent of the grounding of any point in the power system, as shown in Figure 1.

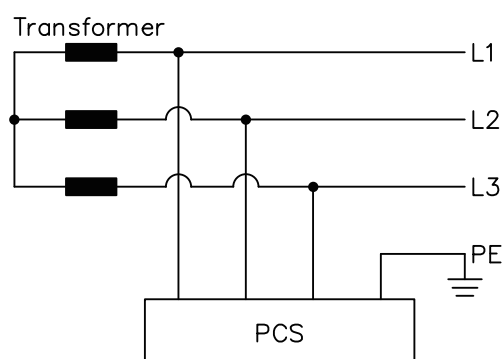

Figure 1 IT power distribution system

3. Appearance

3.1. Appearance and Structure

The structure layout of PCS is as shown in Figure 2, corresponding components illustration please see 01.

The PCS designs front indicator and strip indicator panel. The illustration for front indicator and strip indicator panel please see Table 3.

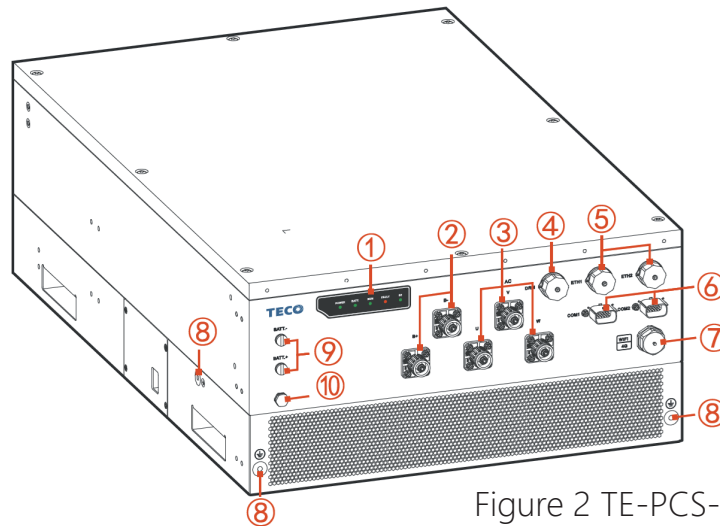



Figure 2 TE-PCS-FM Structure layout diagram

Table 1 Component illustration

No.	Mark	Name	Illustration
①	-	Strip indicator panel	Indicate the work status of PCS.
②	B+/B-	DC terminals	Wiring terminals of DC side.
③	AC U(R) / V(S) / W(T)	AC terminals	Wiring terminals of AC side.
④	DRM	DRM port	Reserved port for DRM function.
⑤	ETH1 / ETH2	Ethernet port	Used to connect with upper-computer. Ethernet is mainly used for LAN monitor, and realize remote monitor.
⑥	COM1 / COM2	Communication port	COM1 : Reserved port for communication. COM2 : Used for BMS communication.
⑦	WIFI / 4G	Used for BMS communication	Used for wireless communication.
⑧		Grounding terminal of wiring side	Used to connect the PCS with ground.
⑨	BAT.+ / VAT. -	Waterproof plug	Reserved port for battery voltage sampling (optional).
⑩	-	Breather valve	Used to balance the pressure difference between inside and outside of the PCS.

3.1.1 Strip indicator panel

The strip indicator panel has five indicator lights (as shown in Figure 3), which can indicate the current operating status of the PCS. The description of these five indicator lights is shown in Table 3.

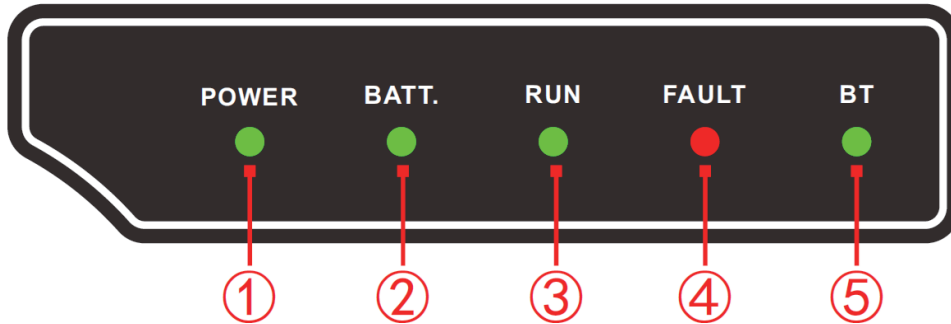

Figure 3 Strip indicator panel

Table 3 Indicator status illustration

①	POWER	Green	Operation power indicator	On: the inner power of the PCS has been established.
				Off: the inner power of the PCS has not been established.
②	BATT.	Green	Battery connection indicator	On: the battery has been connected and meets the work condition.
				Off: the battery voltage does not meet the work condition.
③	RUN	Green	Running status indicator	On: in grid-tied operating status.
				Flicker: standby or OFF.
④	FAUTL	Red	Running status indicator	Off: AC and DC terminals not connected.
				On: there is fault on PCS.
⑤	BT (optional)	Green	Bluetooth indicator	Flicker: there is alarm on PCS.
				Off: there is no fault or alarm.
				On : Bluetooth connection is normal.
				Flicker: Bluetooth waiting for connection.
				Off : Bluetooth power not established.

3.1.2. COM1/COM2 Communication port

The port COM1, COM2 adopt 18Pin signal connector, as shown in Figure 4.

The port COM1 is only for internal debugging, the definition of each pin in COM2 is as shown in Table 4.

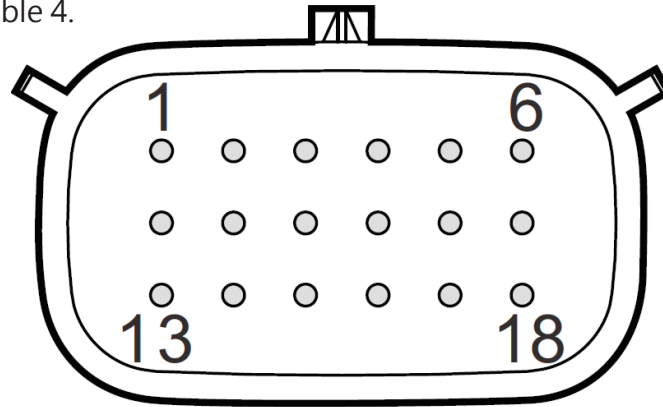

Figure 4 Port diagram of COM1/COM2

Table 4 Pin definition of COM2

Pin	Function definition	Illustration	
Pin1	Passive input dry contact port 1	Pin1 and Pin4 is a group of EPO dry contact port for PCS.	
Pin2	BMS serial communication port	BMS_RS485_B. It is used with Pin5 (RS485_A) together.	
Pin3	BMS CAN communication port	CAN_L. It is used with Pin6 (CAN_H) together.	
Pin4	Passive input dry contact port 1	Pin1 and Pin4 is a group of EPO dry contact port for PCS.	
Pin5	BMS serial communication port	BMS_RS485_A. It is used with Pin2 (RS485_B) together.	
Pin6	BMS CAN communication port	CAN_H. It is used with Pin3 (CAN_L) together.	
Pin7	CAN_H. It is used with Pin3 (CAN_L) together.	Pin7 and Pin8 is a group of EPO dry contact port for PCS. If the ports need to be used, please contact our company.	
Pin8			
Pin9	Upper-computer serial communication port	PC_ISO_A (RS485)	
Pin10		PC_ISO_B (RS485)	
Pin11	Reserved external BMS power supply port	+24V_IOS_BMS	If this function needs to be used, please contact our company.
Pin12		0V	

Pin	Function definition	Illustration	
Pin13	Active input dry contact port	+24V	Pin13 and Pin14 is a group of active EPO dry contact ports for PCS.
Pin14		0V	
Pin15	Reserved external BMS power supply port	+24V_IOS_BMS	If this function needs to be used, please contact our company.
Pin16		0V	
Pin17	Meter communication port (optional)	Meter communication port RS485 A	
Pin18		Meter communication port RS485 B	

3.2. Size

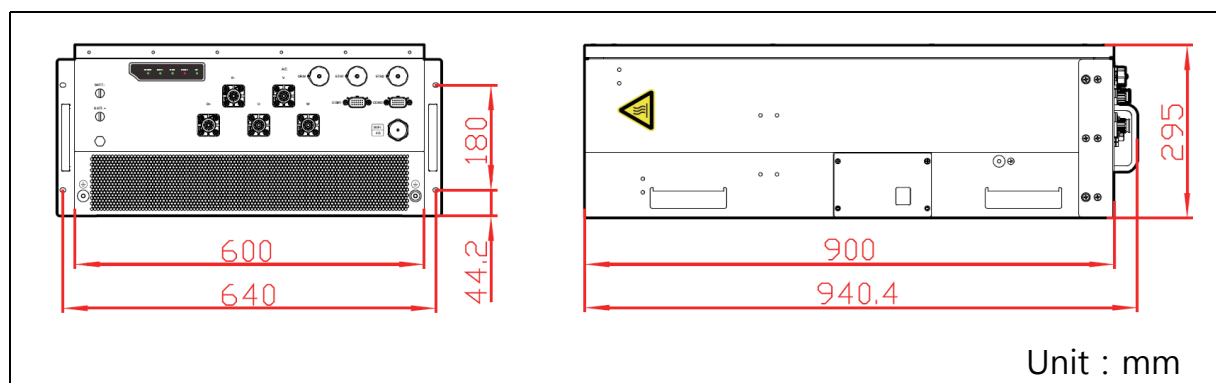

Figure 5 Size (Unit : mm)

4. Working Principle

The external connected battery group of the PCS is connected to the DC bus through the external DC switch. During charging, the current flows from the grid through three-phase rectification to the battery. During discharging, the current pass through the DC bus and then through three-phase inverter and output filtering to generate sinusoidal AC. When off-grid, the AC output is supplied to load, and when grid-tied, the output is fed into the grid, as shown in Figure 6.

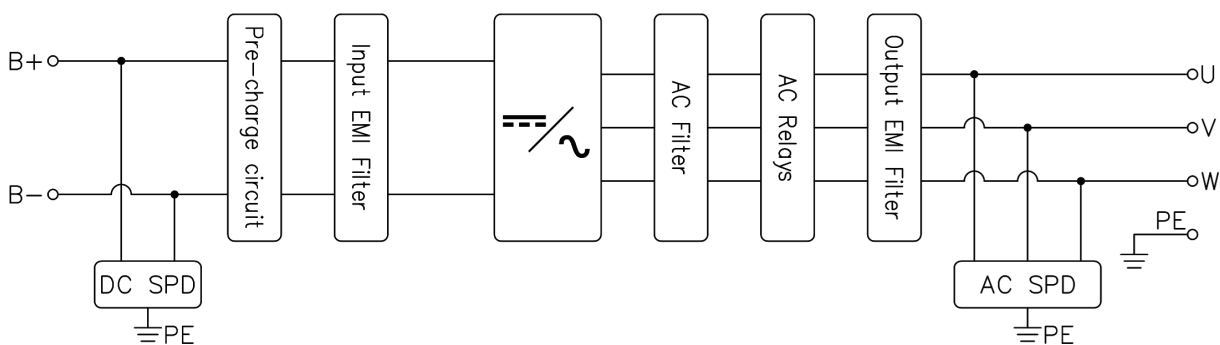

Figure 6 Working principle diagram

4.1. Grid-tied mode

On grid-tied mode, the PCS can realize charge and discharge function.

- Charge includes constant current charging, constant power charging.
- Discharge includes constant power discharging.

Besides, on grid-tied mode, user can set the charge and discharge time through upper-computer.

During grid-tied, the PCS can track the grid frequency automatically, and realize the function of smooth power output, peak shaving, system frequency modulation, load balancing, transient active output emergency response, transient voltage emergency support, improving power quality, etc.

4.2. Off-grid mode

On off-grid mode, the PCS can output the stabilized voltage and frequency. When the grid power down or the PCS is in independent system, it can supply power for load continuously to ensure the normal production and living electricity consumption. At that time, the PCS stay in off-grid status.

5. Grid-tied mode

The PCS has multiple communication methods, the communication to the upper-computer includes Ethernet, RS485, WIFI/4G (optional), and users can easily obtain the current operation data of the PCS. The communication to BMS includes CAN and RS485.

5.1. Communication with Upper-computer

5.1.1. Ethernet Communication

Ethernet is mainly used for local area network monitoring, enabling remote monitoring from the backend. The connection method is shown in Figure 7.

The location is shown in ⑤ of the appearance diagram of the TE-PCS-FM series in Figure 2.

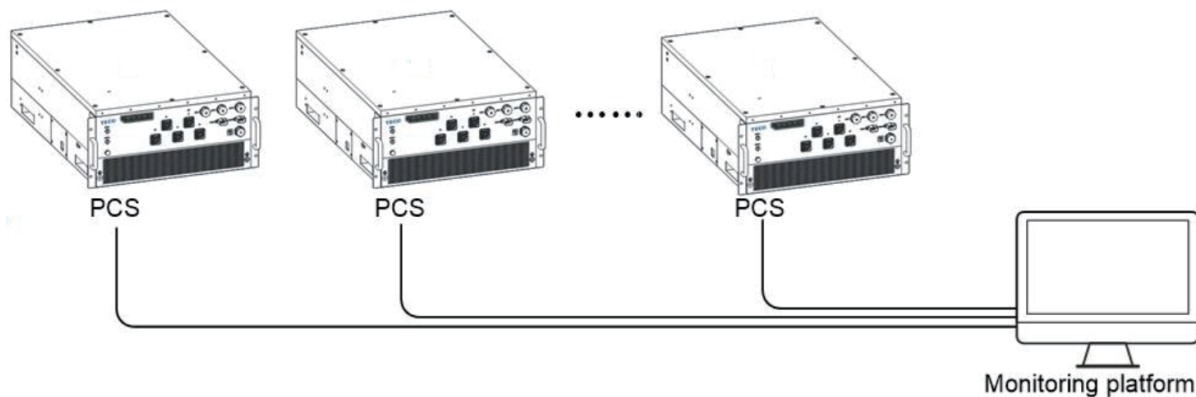

Figure 7 Monitoring via Ethernet (multiple PCSs)

5.1.2. RS485 Communication

RS485 communication is mainly used for local area network monitoring, enabling remote monitoring from the backend. The connection method is shown in Figure 8, and the relevant pin definitions are shown in Table 4_COM2.

The location is shown in Figure 2_TE-PCS-FM series appearance diagram ⑥.



圖8 RS485連接示意圖(多台通訊)

- The A, B of RS485 on each PCS should be connected to monitor platform separately, A,B cannot be mixed.
- If multiple PCS communicate through RS485, please set the communication address of each PCS by WEB.
- The wiring of RS485 communication and input/output should be separated to avoid interfering the communication.

5.1.3. Bluetooth Communication (Optional)

Bluetooth communication is mainly used for display and monitoring.

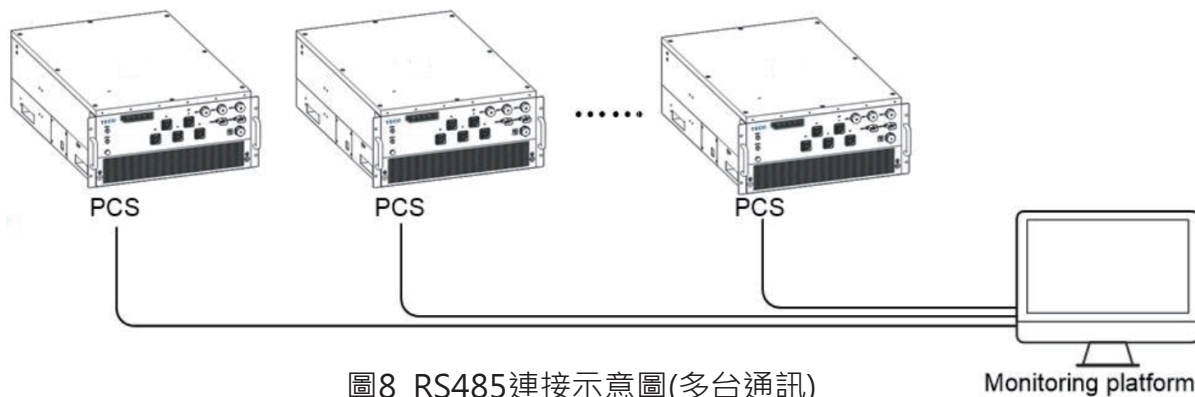
Users can connect to the power conversion system via the web interface on their mobile devices to perform maintenance and monitoring of the power conversion system.

- For web-based usage, you can scan the QR code on the device to view relevant operating instructions.

5.1.4. WIFI/4G Communication (Optional)

WIFI communication is mainly used to display monitor, and the running information of the PCS can be monitored through APP on phone.

The location is shown in ⑦ of the appearance diagram of the TE-PCS-FM series in Figure 2.

5.2. Communication with BMS

The PCS can communicate with battery management system (BMS) through RS485 (pin 5 and pin 2 in COM2) or CAN (pin 6 and pin 3 in COM2) to monitor the real-time battery status, at the same time, it can alarm and protect for the fault according to the battery status, which can enhance the batteries' safety.

- The A, B of RS485 on each PCS should be connected to monitor platform separately, A, B cannot be mixed.
- The H, L of CAN on each PCS should be connected to monitor platform separately, H, L cannot be mixed.
- If multiple PCS communicating, please set the communication address of each PCS by WEB, details please contact the manufacturer.
- The wiring of communication and input/output should be separated to avoid interfering the communication.

5.3. Meter Communication (Optional)

The meter communication port is used to communicate with the smart meter to implement the backflow prevention function. The relevant pin definitions are shown in Table 4_COM2. The system wiring is shown in Figure 9.

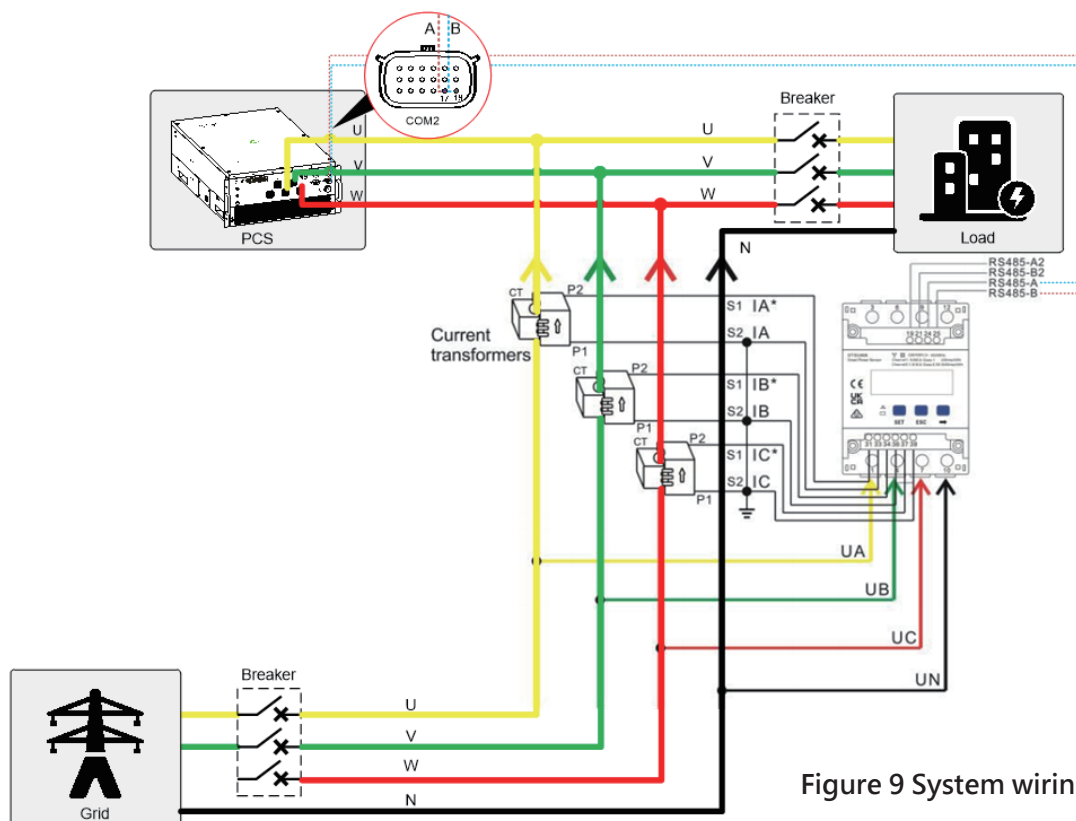

Figure 9 System wiring diagram

※Note the connection direction of the flow meter.

6. Startup and Shutdown

6.1. Check Before Startup

Before first startup, please check the following items first.

- Ensure that the ventilation around the PCS is good.
- Ensure that all safety marks and warning labels are pasted firmly and clear to see.
- Ensure that the PCS is properly installed and fastened.
- Ensure that the connection of the PCS and other accessories is right.
- Ensure that the external DC switch and AC breaker are all OFF.
- Ensure that the grid voltage is in accordance with the required grid-tied voltage of the PCS.
- Ensure that the polarity connection of battery is right.

6.2. Start the PCS



DANGER

Damaged device or device fault may cause electric shock or fire!

- Before operation, please check if the PCS is damaged or has other danger.
 - Check the external device or circuit connection and see if it is safe.
-

After ensure the PCS is normal, start the PCS according to following steps.

- Step1. Close the external DC switch of the PCS, 1 minute later, the indicators on strip indicator panel and front panel will light on.
- Step2. Close the external AC breaker between the PCS and grid, the red indicator on strip indicator panel and front panel light off.
- Step3. The red channel (FAULT), set up the conditions for proper operation via the host or web.
- Step4. Go to the host or web interface and select "Power On". PCS will then enter the boot process.
- Step5. After a period of time, the PCS will be grid-tied normally. The indicators on strip indicator panel and front panel will be on or flicker according to running status.

6.3. Shut Down the PCS



DANGER

When the PCS is operating normally, it is strictly prohibited to disconnect the external switches at DC and AC side with load to avoid the risk of arc damaging the switch. In severe cases, the PCS may be damaged.

- Step1. Set the PCS to OFF through the APP monitor platform upper-computer.
- Step2. Switch off the external AC breaker between the PCS.
- Step3. Switch off the external DC switches on the PCS, after a while, the indicators on strip indicator panel and front panel light off.

7. WEB Operation

7.1. Communication Wire Connection

The PCS network interface is connected to the Ethernet cable at one end (the interface location is shown in Figure 2_TE-PCS-FM series appearance diagram ⑤), and the computer's Ethernet interface is connected to the other end to establish communication between the PCS and the computer.

7.2. Communication Settings

Change the network configuration of the computer. Open the Internet protocol version 4 (TCP/IPv4) properties page, select "Use the following IP address", and set the IP address to 192.168.28.200, set subnet mask to 255.255.255.0, other settings keep default, and then click "OK" to complete the setting, as shown in Figure 10.



Figure 10 Set IP address of computer

7.3. Login

7.3.1. Open the browser (Google Chrome browser is recommended to use), enter the IP address 192.168.28.240 into the search box, click Enter button to enter login page.

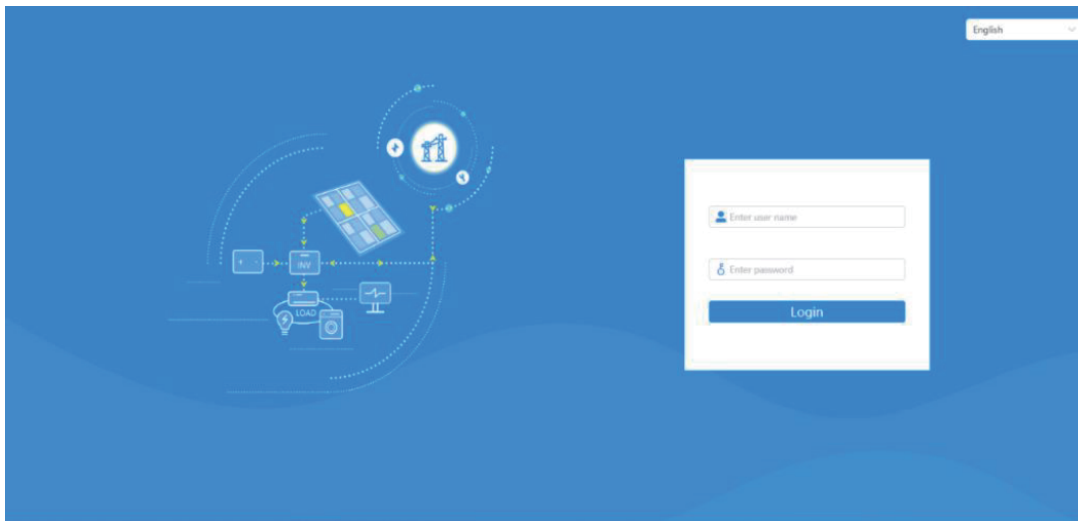

Figure 11 Login page

7.3.2. Enter user name and password, and then click Login button, the page will enter the system info page of running info, as shown in Figure 12.

Note : The language can be changed at the right top corner.

Initial account

user name	user
corresponding password	111

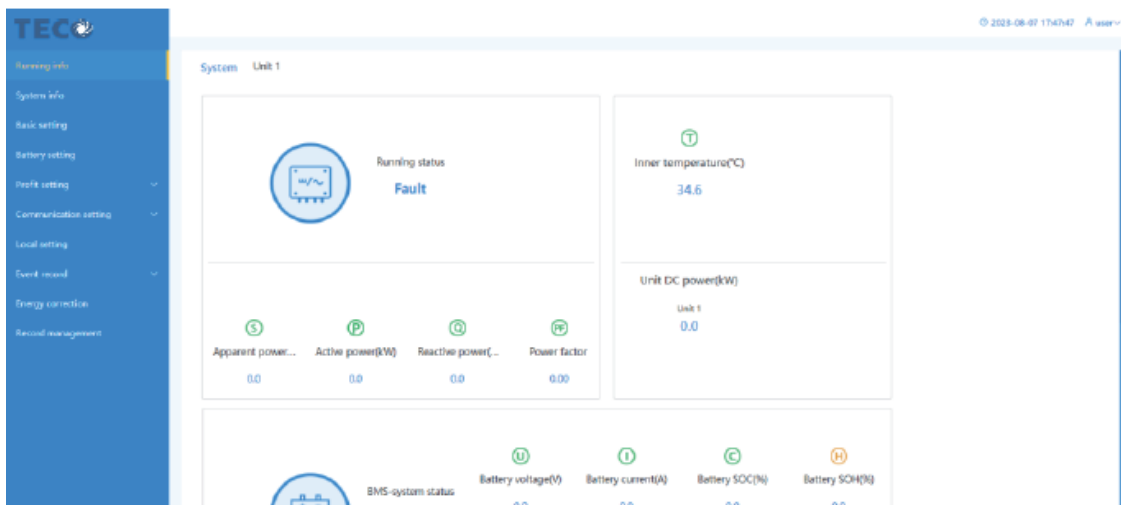

Figure 12 Running info page

- The function status of running info page is as follows.
- Running status: shows current operation status, as shown in Table 5.
- Shows total output apparent power (kVA), total output active power (kVA), total output reactive power (kVar) and power factor of whole energy storage system at that time.
- Unit DC power: shows the DC power of each unit.
- Inner temperature: shows the max. inner temperature of each unit.
- Move the page down, it will show the battery running info, as shown in Figure 13.

Table 5 Running status illustration

Running status	Meaning
Charge	PCS power on and charging
Discharge	PCS power on and discharging
Charge derating	PCS power on and charge derating for temperature.
Discharge derating	PCS power on and discharge derating for temperature.
Standby	PCS power on and without fault, without charge and discharge power.
Halt	PCS power off and stop operating.
Fault	There is fault on the PCS, click current fault, it will shows the fault details.

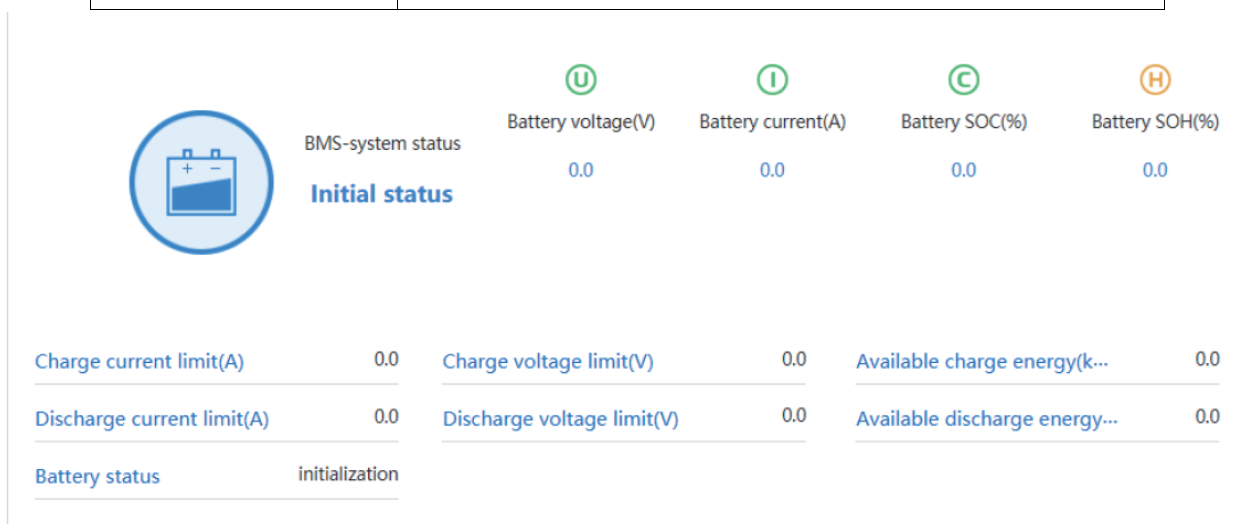

Figure 13 Unit battery running info page



The page contains many parameters that related with the operation of PCS. All the modification for the parameters should be done by specified professional. For the parameters that not clear with the meaning, please see the user manual or consult related engineer of our company, please do not change the setting at will.

7.4. Unit Running Info

In the running info page, click the Unit 1 icon of, as shown in Figure 14.

The system and unit buttons allow for quick switching between viewing system/unit operation information.

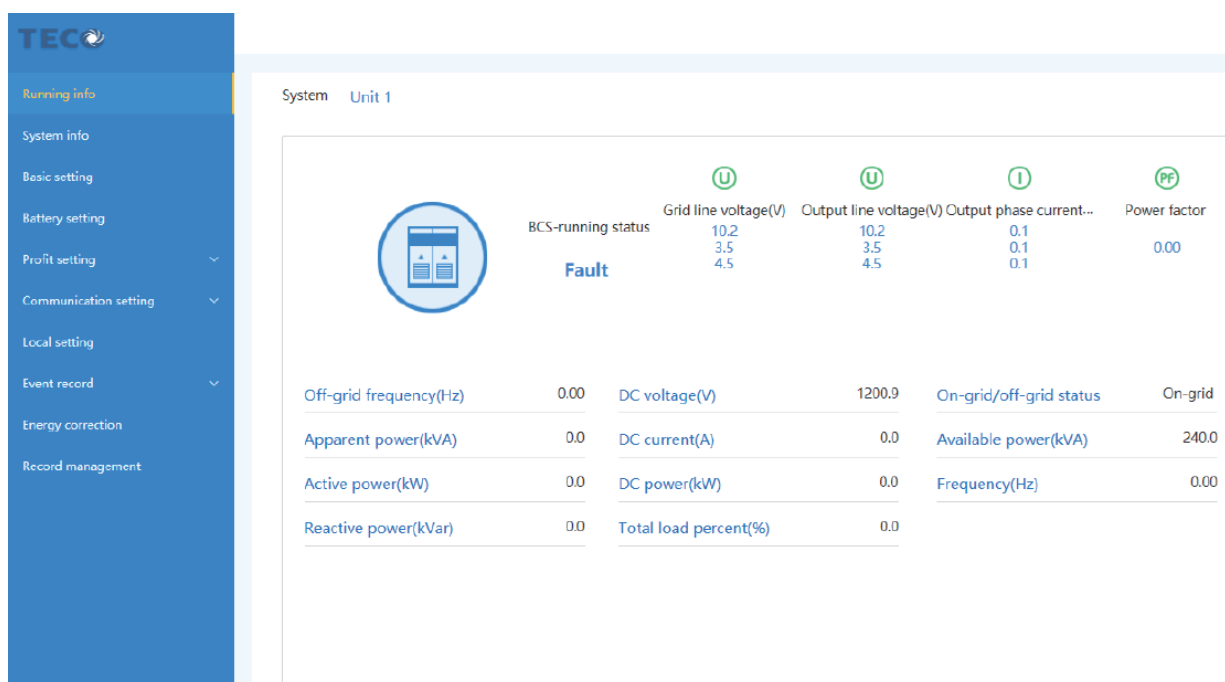

Figure 14 Unit running info page

7.5. System Info

Click System info at left function menu bar (as shown in Figure 15), it will enter the system info page, as shown in Figure 16.



Figure 15 Function menu bar

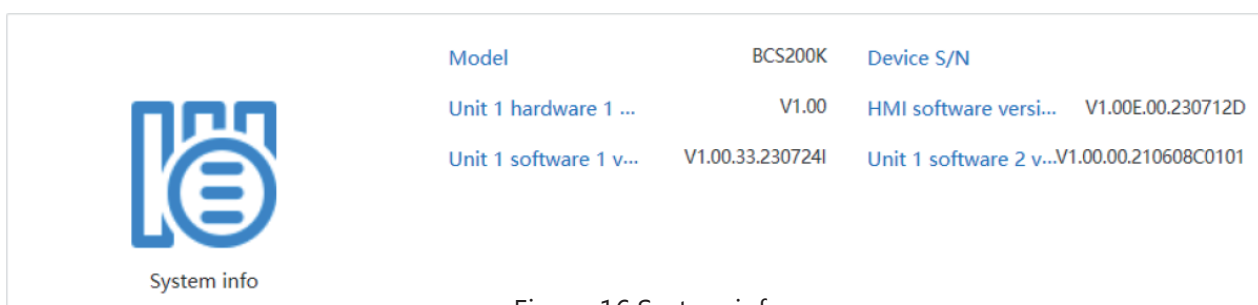

Figure 16 System info page

In the system info page, you can get the model, S/N, hardware version, HMI software version, control software, control software, etc.

7.6. Basic Setting

Click Basic setting at left function menu bar, it will enter the basic setting page, as shown in Figure 17, Figure 18.

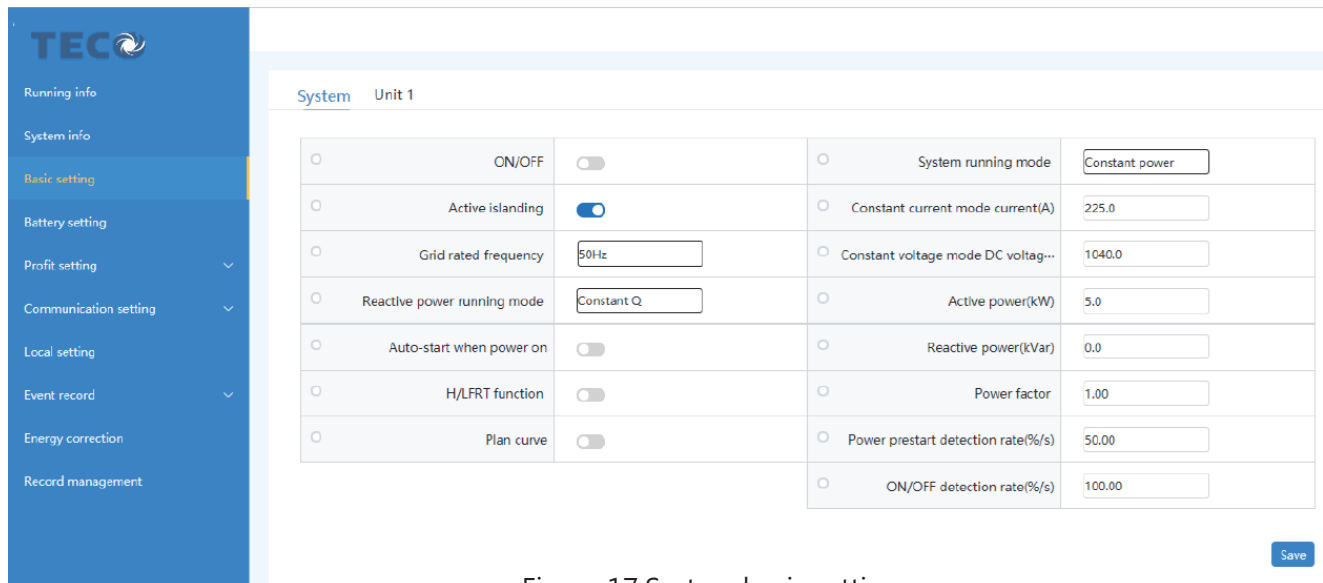

Figure 17 System basic setting page

In the page, you can set the related function items, such as active islanding, H/LVRT function, auto-start when power on, plan curve, reactive power running mode, system running mode, current of constant current mode, DC voltage of constant voltage, power factor, ON/OFF detection rate, power slow-start rate and active power, reactive power.

After setting up, click the "Save" button in the lower right corner for the settings to take effect.

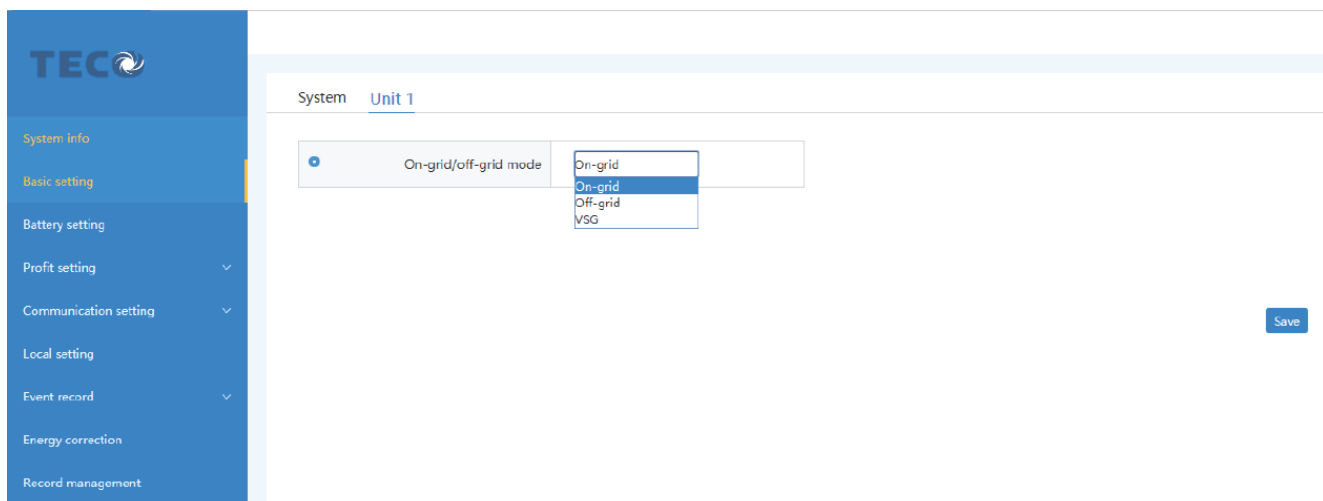

Figure 18 Basic setting page of unit 1

In addition, you can also set the switching between network connection, offline connection, and VSG functions on this page.

7.6.1. ON Setting

In basic setting page, click the gray button of Power on/off to blue , and click the small circle to , and then , click Save button, it will popup the confirmation window, as shown in Figure19, click Confirm button, that means the setting is successful.

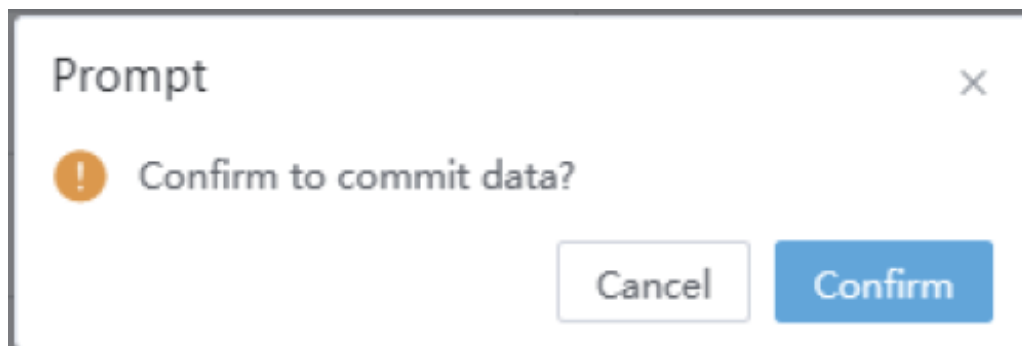

Figure 19 Save confirmation window

7.6.2. OFF Setting

In the basic setting page, click the blue button of Power on/off to gray , and click the small circle to , and then , click Save button, it will popup the confirmation window, as shown in Figure19, click Confirm button, that means the setting is successful.

7.7. Battery Setting

Click Battery setting at left function menu bar, it will enter the battery setting page, as shown in Figure20.

In the page, you can set the related protection info of battery, such as equalized charge voltage, discharge ending voltage, battery over-voltage protection, battery under-voltage alarm, battery under-voltage protection, battery under-voltage protection (heavy load), battery over-voltage return difference, battery under-voltage return difference (heavy load), discharge ending return difference.

After setting, click Save button, it will popup the confirmation window, as shown in Figure 19, click Confirm button, that means the setting is successful.

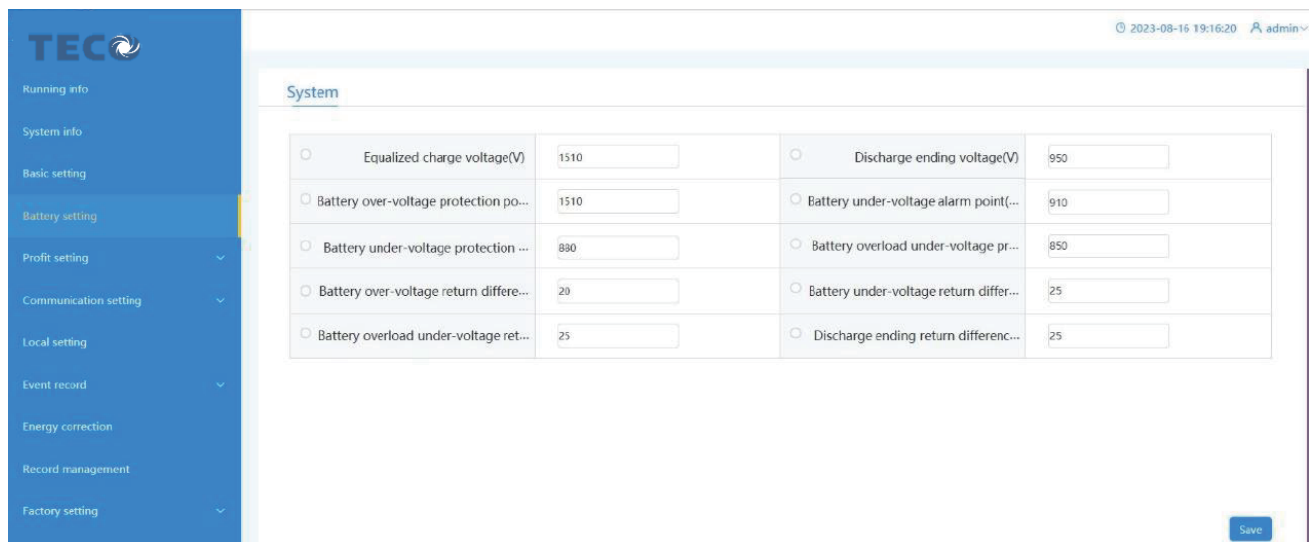

Setting	Value	Setting	Value
Equalized charge voltage(V)	1510	Discharge ending voltage(V)	950
Battery over-voltage protection po...	1510	Battery under-voltage alarm point(...)	910
Battery under-voltage protection ...	880	Battery overload under-voltage pr...	850
Battery over-voltage return differ...	20	Battery under-voltage return differ...	25
Battery overload under-voltage ret...	25	Discharge ending return differenc...	25

Figure 20 Battery setting page

7.8. Profit Setting

Click profit setting at left function menu bar, it will enter the plan curve page, as shown in Figure 21.

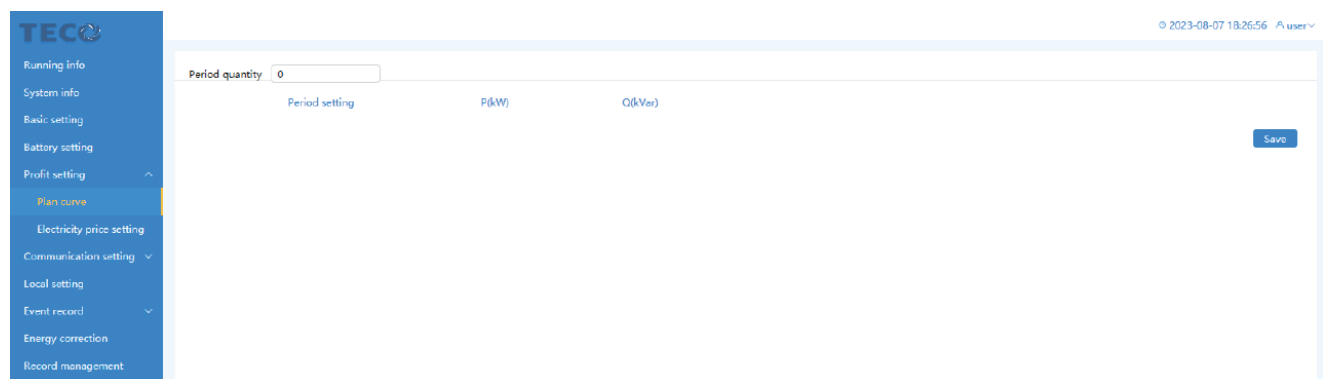

Period quantity:

Period setting P(kW) Q(kVar)

Figure 21 Plan curve page

7.8.1. Plan Curve Setting

In the "Complete Quantity Setting" section (as shown in Figure 21), set the required number of plans. The corresponding plan quantity setting section will then be displayed below, as shown in Figure 22.

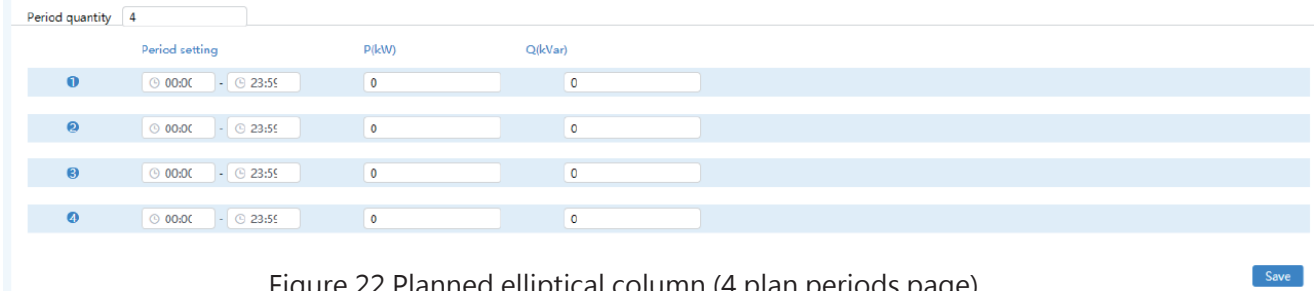

Period setting	P(kW)	Q(kVar)
00:00 - 23:59	0	0
00:00 - 23:59	0	0
00:00 - 23:59	0	0
00:00 - 23:59	0	0

Figure 22 Planned elliptical column (4 plan periods page)

Then, click the Save button at the right bottom corner, that means the setting is saved successfully.

7.8.2. Electricity Price Setting

Click the electricity price setting button under profit settings to enter the electricity price setting page, as shown in Figure 23.

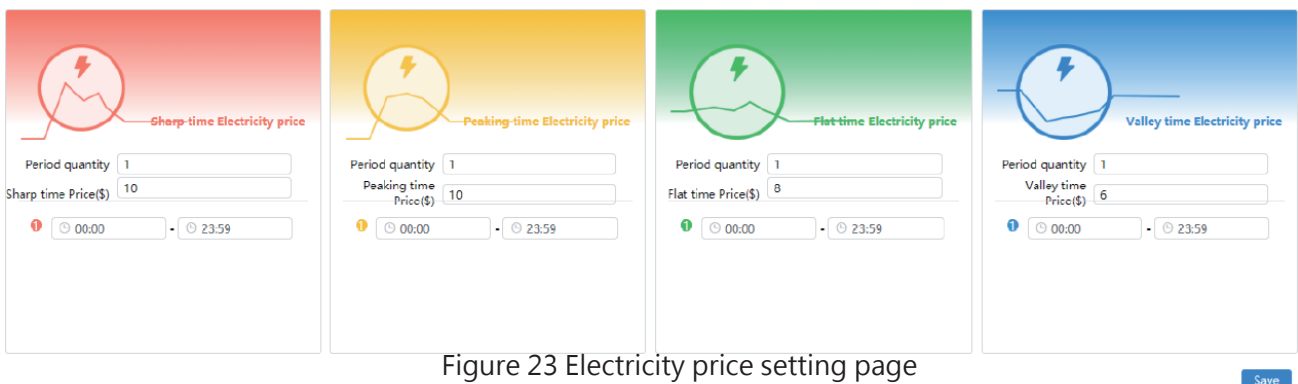

Sharp-time Electricity price	Peaking-time Electricity price	Flat-time Electricity price	Valley time Electricity price
Period quantity: 1 Sharp time Price(\$): 10 00:00 - 23:59	Period quantity: 1 Peaking time Price(\$): 10 00:00 - 23:59	Period quantity: 1 Flat time Price(\$): 8 00:00 - 23:59	Period quantity: 1 Valley time Price(\$): 6 00:00 - 23:59

Figure 23 Electricity price setting page

On this page, you can set electricity prices for peak, off-peak, and sub-peak periods. After entering the number of periods, the corresponding period settings will pop up, as shown in Figure 24.

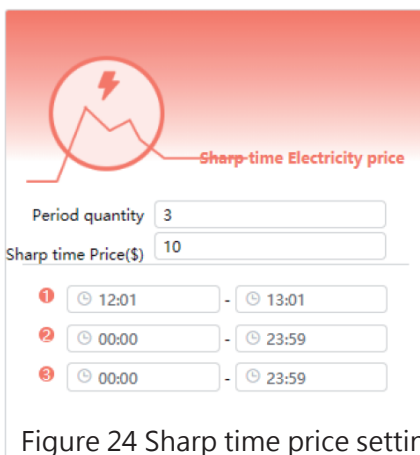

Sharp-time Electricity price

Period quantity: 3

Sharp time Price(\$): 10

12:01 - 13:01

00:00 - 23:59

00:00 - 23:59

Figure 24 Sharp time price setting page

Then, click the Save button at the right bottom corner, that means the setting is successful. The time periods cannot overlap or intersect. If the time periods overlap, an error message will pop up.

7.9. Communication Setting

Click on "Communication Settings" in the left-hand menu to access the communication settings page. On this page, users can modify local network parameters (as shown in Figure 25), Modbus communication parameters (as shown in Figure 26), 61850 communication parameters (as shown in Figure 27), and 104 communication parameters (as shown in Figure 28).

Network port1

IP	192.168.28.240	Subnet mask	255.255.255.0
Gateway	192.168.0.1		

Network port2

IP	192.168.28.241	Subnet mask	255.255.255.0
Gateway	192.168.28.1		

[Save](#)

Figure 25 Local network setting page

Modbus RTU1

Rtu address	1	Rtu baudrate	9600
Rtu remote communication abnormal protection	<input type="radio"/> ON <input checked="" type="radio"/> OFF	Remote control function	<input checked="" type="radio"/> ON <input type="radio"/> OFF

Modbus RTU2

Rtu address	1	Rtu baudrate	9600
Rtu remote communication abnormal protection	<input type="radio"/> ON <input checked="" type="radio"/> OFF	Remote control function	<input checked="" type="radio"/> ON <input type="radio"/> OFF

Modbus TCP

Tcp remote communication abnormal protection	<input type="radio"/> ON <input checked="" type="radio"/> OFF	TCP remote control function	<input type="radio"/> ON <input checked="" type="radio"/> OFF
--	---	-----------------------------	---

Common

Remote communication timeout(s)	10		
---------------------------------	----	--	--

[Save](#)

Figure 26 Modbus setting page

In Modbus communication setting, enabling Modbus RTU1 will monitor via RS485, and Modbus RTU2 as the optional function, enabling Modbus TCP will monitor via Ethernet. In Modbus communication setting, enabling Modbus RTU1 will monitor via RS485, and Modbus RTU2 as the optional function, enabling Modbus TCP will monitor via Ethernet.

MMS remote communication timeout(s) 10

Client	IP	Timeout protection
1	192.168.28.129	<input type="radio"/> ON <input checked="" type="radio"/> OFF
2	0.0.0.0	<input type="radio"/> ON <input checked="" type="radio"/> OFF
3	0.0.0.0	<input type="radio"/> ON <input checked="" type="radio"/> OFF
4	0.0.0.0	<input type="radio"/> ON <input checked="" type="radio"/> OFF

GOOSE remote communication timeout(s) 10

GOOSE timeout protection(s) ON OFF

[Save](#)

Figure 27 61850 setting page

Remote communication timeout(s)	<input type="text" value="10"/>	Remote signalling base address	<input type="text" value="1"/>
Telemetry base address	<input type="text" value="16385"/>	Remote control base address	<input type="text" value="24577"/>
Remote regulation base address	<input type="text" value="25089"/>		

Client	IP	Redundancy group	Timeout protection
1	<input type="text" value="0.0.0.0"/>	<input type="text" value="0"/>	<input type="radio"/> ON <input checked="" type="radio"/> OFF
2	<input type="text" value="0.0.0.0"/>	<input type="text" value="0"/>	<input type="radio"/> ON <input checked="" type="radio"/> OFF
3	<input type="text" value="0.0.0.0"/>	<input type="text" value="0"/>	<input type="radio"/> ON <input checked="" type="radio"/> OFF
4	<input type="text" value="0.0.0.0"/>	<input type="text" value="0"/>	<input type="radio"/> ON <input checked="" type="radio"/> OFF

Figure 28 104 setting page

7.10. Local Setting

Select "Local Settings" in the left-hand menu to access the local settings page. This page includes NTP time synchronization, time synchronization period, NTP server, date settings, time settings, and time zone settings. When NTP time synchronization is set to "Off," users can set the time and adjust it accordingly, as shown in Figure 29. When NTP time synchronization is set to "On," users can configure the NTP server, as shown in Figure 30.

NTP time synchronize	<input type="radio"/> ON <input checked="" type="radio"/> OFF	Time synchronize cycle(s)	<input type="text" value="10"/>
Time zone setting	<input type="text" value="GMT+8:00"/>	Time setting	<input type="text" value="© 2023-08-07 18:36:34"/>

Figure 29 Local setting page 1

NTP time synchronize	<input checked="" type="radio"/> ON <input type="radio"/> OFF	Time synchronize cycle(s)	<input type="text" value="10"/>
Time zone setting	<input type="text" value="GMT+8:00"/>	NTP server	<input type="text" value="0.0.0.0"/>

Figure 30 Local setting page 2

7.11. Event Record

Click Event record at the left function menu bar, it will enter the current fault page. User can check the current fault, history fault, user log, power scheduling log.

- Current fault page shows the fault of all units at current moment.
- History fault shows the history fault of all units.
- User log shows all content and time of setting that performed on WEB.
- Power scheduling log shows the active power, reactive power and power factor that set on WEB.

7.12. Energy Correction

Clicking "Energy Calibration" in the left-hand menu will take you to the energy calibration page, as shown in Figure 31. Users can calibrate the total charging energy and total discharging energy of the PCS.

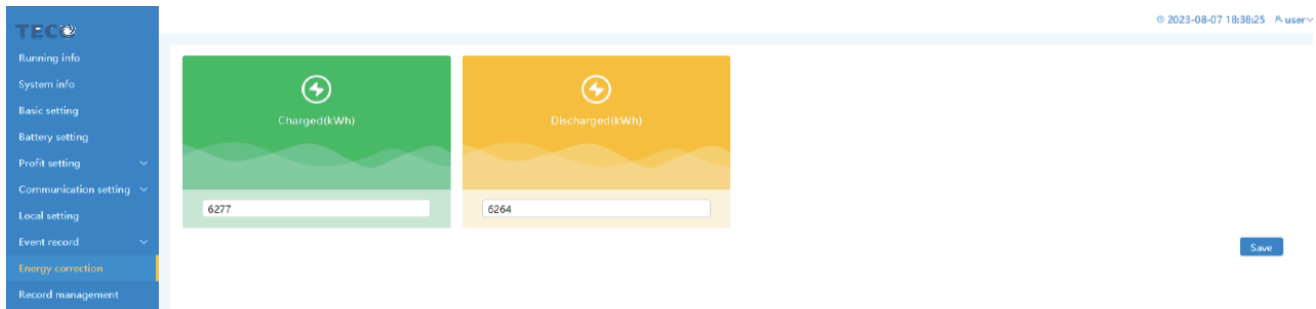

Figure 31 Energy correction page

7.13. Record Management

Click on "Record Management" in the left-hand menu to access the record management page, as shown in Figure 32. On this page, users can export historical fault records, user logs, power dispatch logs, energy data, and fault waveform captures.

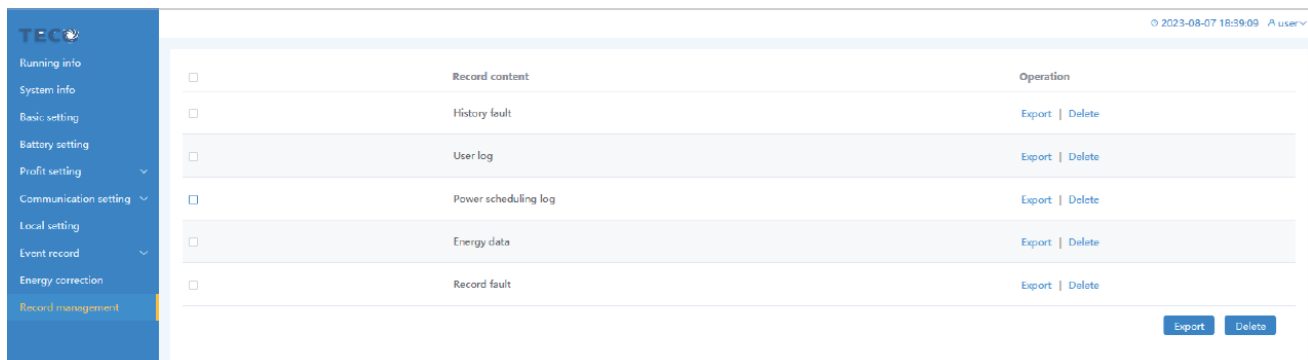



Figure 32 Record management page

7.14. Modify Password

Clicking the  icon in the upper right corner will display the logout and change password options, as shown in Figure 33. Clicking the logout option will log you out of the login page; clicking the change password option will take you to the change password page, as shown in Figure 34, where you can set your password.

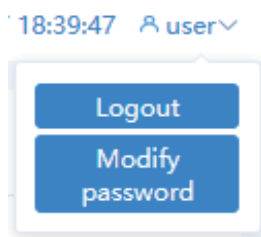

Figure 33 Logout and modify password options page

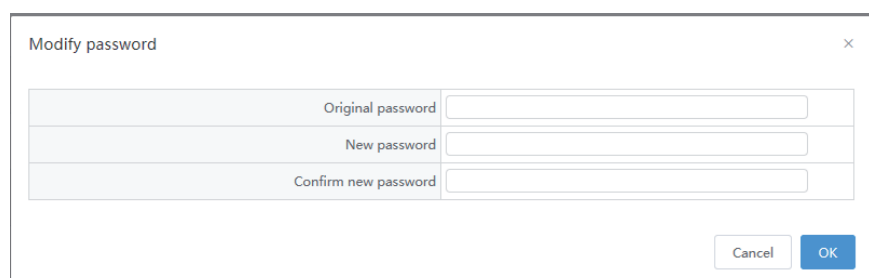

Figure 34 Modify password page

8. Maintenance and Troubleshooting

8.1. Maintenance

 CAUTION

For human safety, before check and maintenance, disconnect the external AC switch and battery switch firstly, and then switch off the and DC switch on the PCS. Wait for 20 minutes, measure the inner DC bus voltage by multimeter and ensure the voltage below 10V, and then the maintenance can be done.

8.1.1. Maintenance Details and Period

To ensure the PCS works in best condition, we suggest maintaining the PCS regularly.

Table 6 Check list

Item	Check method	Maintenance period
Cleanness of system	Check if there is dust or sundries on air outlet holes or heat sink. Clean the air outlet holes and heat sink if necessary.	Every 3 to 6 months (it is decided by the dust of the environment)
Electrical connection	Check if the wiring is loose or dropping. Check if there is damage on the cables, especially the surface touching with metal, if damaged, please maintain it in time.	Every half or one year
Fan	Check if there is abnormal noise on fan while running. Check if the blade of fan has crack. If necessary, replace the fan refer to Maintenance Guide	Every year
LED indicator	If the surface of the LED indicators is too dirty to read, clean it with a damp cloth.	In necessary

CAUTION

Do not clean the PCS with any solvent, abrasive material or corrosive material.

WARNING

During running, please don't touch the surface to avoid scald. Shut down the PCS and wait until it cooling down, then do the maintenance.

8.1.2. Clean wind inlet & outlet holes

During operating, the PCS will generate large heat, so, the PCS designs the forced wind-cooling way. To ensure good ventilation, it is necessary to check the wind inlet & outlet holes and keep them unblocked. If necessary, a soft brush can be used to clean the wind inlet & outlet holes.

8.1.3. Fan maintenance

⚠ WARNING

Before maintenance, shut down the PCS and disconnect all power input. Wait for 20min at least, after the inner capacitor discharge completely, the maintenance can be done.

The maintenance and replacement for fan only can be done by professional electric person.

The inner fans are used for cooling and heat dissipation while operating. If the fans cannot work normally, it will affect the PCS efficiency or cause derating running. So, keep the fans clean and replace the damaged fan in time. The fan's cleanness and replacement procedure as follows.

Step1. Shut down the PCS (see 6.3 Shut down PCS).

Step2. Loosen the screws of the fan module, as shown in Figure35.

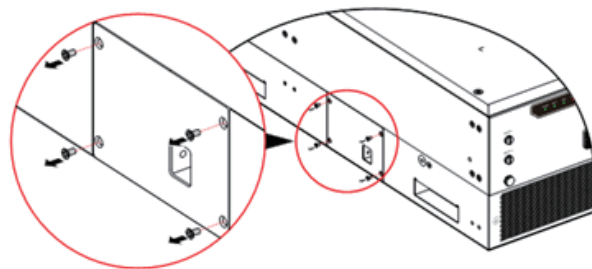

Figure 35 Loosen the screws of fan cover

Step3. Gently pull out the fan module and loosen the fan connector, as shown in Figure36

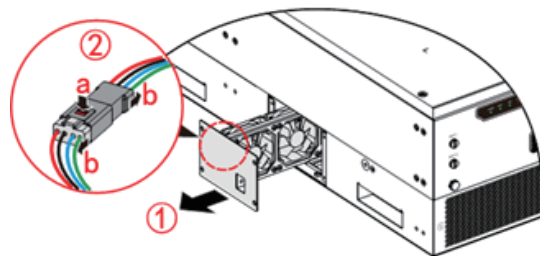

Figure 36 loosen the wiring of fan module

Step4. Pull out the fan module, clean the fan by brush or cleaner or replace the damaged fan.

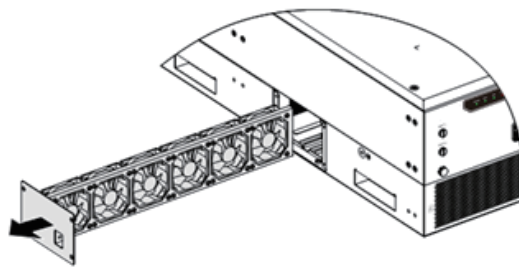

Figure 37 Pull out fan module

Step5. Install the fan module in reversed order and lock the screws, restart the PCS
(see 6.2 Start PCS).

8.2. Troubleshooting

If a malfunction occurs, the red indicator light on the front panel and the fault indicator light on the bar indicator panel will illuminate, and you can view the fault details on the host computer. In this case, the PCS may stop operating.

Fault conditions are shown in Table 7.

Table 7 Troubleshooting list

No.	Fault information	Solution
1	Grid over-voltage	Please check the grid, once the grid recover normal, it will recover normal operation.
2	Grid under-voltage	Please check the grid, once the grid recover normal, it will recover normal operation.
3	Over-frequency abnormal	Please check the grid, once the grid recover normal, it will recover normal operation.
4	Under-frequency abnormal	Please check the grid, once the grid recover normal, it will recover normal operation.
5	Phase sequence abnormal	After ensure that the connection of grid and the PCS is disconnected, check if the AC wire is correspond to each phase of U/V/W one by one.
6	Phase lock abnormal	Check the grid, if the grid recovers normal, the phase lock abnormal still exist, please contact local dealer or service centre.
7	AC grounding abnormal	Shut down the PCS, wait until the inner PCS discharged completely, check if there is short circuit to ground at AC side.
8	Insulation impedance abnormal	Check if the insulation resistance of battery group's positive and negative to ground is too low; Check if the surrounding environment is too wet; Check if the inner grounding is loose. If above are all normal, please contact local dealer or service centre.
9	Leakage current abnormal	Check if the insulation resistance of battery group's positive and negative to ground is too low; Check if the surrounding environment is too wet; Check if the inner grounding is loose. If above are all normal, please contact local dealer or service centre.

No.	Fault information	Solution
10	Temperature control switch fault	Check if the heat sink of the PCS is blocked; Check if the environment of the PCS is too high or too low; If above are all normal and the fault still exist, please contact local dealer or service centre.
11	Inner over-temperature	Check if the heat sink of the PCS is blocked; Check if the environment of the PCS is too high or too low; If above are all normal and the fault still exist, please contact local dealer or service centre.
12	Heat sink over-temperature	Check if the heat sink of the PCS is blocked; Check if the environment of the PCS is too high or too low; If above are all normal and the fault still exist, please contact local dealer or service centre.
13	Power module over-temperature	Check if the heat sink of the PCS is blocked; Check if the environment of the PCS is too high or too low; If above are all normal and the fault still exist, please contact local dealer or service centre.
14	Remote communication abnormal	Check if the communication wire is well connected or reverse connected. Please set the address and baud rate correctly.
15	Inner CAN communication abnormal	After the PCS restarted, if the fault still exists, please contact local dealer or service centre.
16	Parallel communication wire abnormal	Check if the communication wire is well connected or reverse connected. Please set the address and baud rate correctly.
17	Overload protection	Please set the load properly.
18	Overload alarm	Please set the load or grid-tied power properly.
19	Short circuit protection	Check if the AC wiring is short circuit, if normal, but the fault still exists, please contact local dealer or service centre.
20	Softstart abnormal	After the PCS restarted, if the fault still exists, please contact local dealer or service centre.
21	Main contactor abnormal	After the PCS restarted, if the fault still exists, please contact local dealer or service centre.
22	Output voltage abnormal	After the PCS restarted, if the fault still exists, please contact local dealer or service centre.

No.	Fault information	Solution
23	Output voltage not meet the off-grid condition	Check if the setting of grid-tied/off-grid mode is right. If the setting is right, the fault still exists, please contact local dealer or service centre.
24	Inverter software over-current	Check if the AC wiring is short circuit; Check if the setting of software over-current value is proper; If above are all normal and the fault still exist, please contact local dealer or service centre.
25	Inverter hardware over-current	Check if the AC wiring is short circuit; If the connection is normal and the fault still exist, please contact local dealer or service centre.
26	Battery over-voltage	Check if the battery voltage is normal; Check if the parameters setting are right; If above are all normal and the fault still exist, please contact local dealer or service centre.
27	Battery under-voltage (with light load)	Check if the battery voltage is normal; Check if the parameters setting are right; If above are all normal and the fault still exist, please contact local dealer or service centre.
28	Battery under-voltage (with heavy load)	Check if the battery voltage is normal; Check if the parameters setting are right; If above are all normal and the fault still exist, please contact local dealer or service centre.
29	DC bus over-voltage	Check if the battery voltage is normal, if normal, the fault still exist, please contact local dealer or service centre.
30	DC softstart abnormal	After the PCS restarted, if the fault still exists, please contact local dealer or service centre.
31	DC main contact abnormal	After the PCS restarted, if the fault still exists, please contact local dealer or service centre.
32	Battery reverse connected	Check if the DC wiring is proper.
33	Battery voltage not meet the charge condition	Check if the battery setting of the PCS is right.
34	DC software over-current	Check if the setting of DC over-voltage is proper, if the setting is right, but the fault still exists, please contact local dealer or service centre.
35	DC hardware over-current	After the PCS restarted, if the fault still exists, please contact local dealer or service centre.

No.	Fault information	Solution
36	Bus quick under-voltage	After the PCS restarted, if the fault still exists, please contact local dealer or service centre.
37	SPD abnormal	If the fault always exists, please contact local dealer or service centre.
38	Battery under-voltage alarm	Check if the battery voltage is normal; Check if the parameters setting are right; If above are all normal and the fault still exist, please contact local dealer or service centre.
39	Grid voltage unbalance alarm	Check if the grid voltage is unbalance, If the fault still exist, please contact local dealer or service centre.
40	BMS charge disabled	After the inner PCS discharged completely, check the BMS, if the fault still exists, please contact the battery manufacturer.
41	BMS discharge disabled	After the inner PCS discharged completely, check the BMS, if the fault still exists, please contact the battery manufacturer.
42	BMS alarm	After the inner PCS discharged completely, check the BMS, if the fault still exists, please contact the battery manufacturer.
43	BMS standby	After the inner PCS discharged completely, check the BMS, if the fault still exists, please contact the battery manufacturer.
44	BMS system abnormal	After the inner PCS discharged completely, check the BMS, if the fault still exists, please contact the battery manufacturer.
45	BMS communication abnormal	After the inner PCS discharged completely, check the BMS, if the fault still exists, please contact the battery manufacturer.

CAUTION

If the PCS has an alarm mentioned in Table7 please shut down PCS ,5 minutes later, restart the PCS



TECO Electric & Machinery Co., Ltd.

5F, No. 19-9, San Chong Rd., Nan-Kang, Taipei 11501, Taiwan (R.O.C.)
Tel 886-2-26553333 ext 3563



About TECO



About IE

PO4 HM260053